

eLektor **BONUS**

design > share > earn

533B
SINCE 1961

FOCUS ON

Prototyping, Production & Components

Andonstar AD409 Pro-ES HDMI Digital Microscope

It's Tall and Has an Endoscope



PECULIAR

PARTS

Unusual ICs

Infographics

Prototyping &
Production

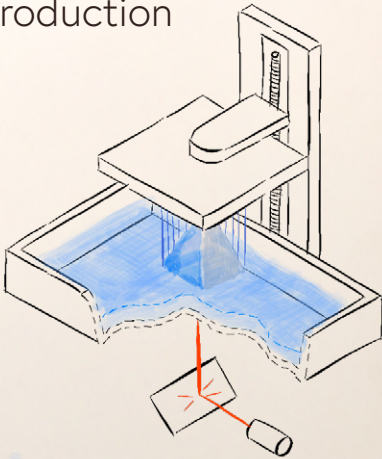

Creating an ESP32 Project With PlatformIO

An Introductory Guide
for Beginners

```
1 #include <Arduino.h>
2
3 // put function declarations here
4 int myfunction(int, int);
5
6 void setup() {
7   // put your setup code here, to run once:
8   int result = myfunction(2, 3);
9 }
10
11 void loop() {
12   // put your main code here, to run repeatedly:
13 }
14
15 // put function definition here
16 int myfunction(int x,
17               int y) {
18   return x * y;
19 }
```

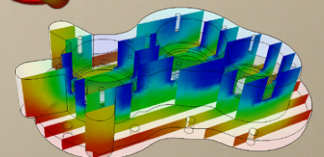
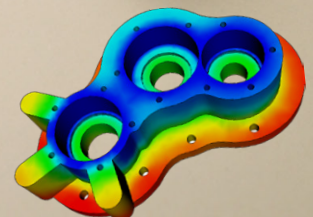
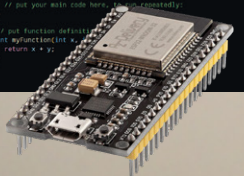

Open-Source Tools

Antenna Simulator,
Component Management,
Calculator, and More

Join the Elektor Community



Take out a
membership!

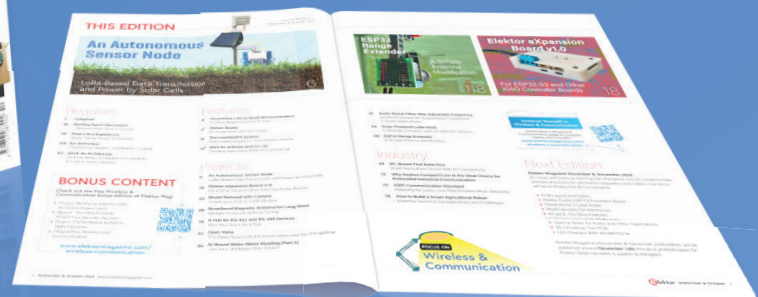

- ✓ The Elektor web archive from 1974!
- ✓ 8x Elektor Magazine (print)
- ✓ 8x Elektor Magazine (digital)
- ✓ 10% discount in our web shop and exclusive offers
- ✓ Access to more than 5,000 Gerber files



Also available

The Digital
membership!



- ✓ The Elektor web archive from 1974!
- ✓ 8x Elektor Magazine (digital)
- ✓ 10% discount in our web shop and exclusive offers
- ✓ Access to more than 5,000 Gerber files



www.elektormagazine.com/member



CONTENTS

- 3 Colophon**
- 4 Creating an ESP32 Project With PlatformIO**
An Introductory Guide for Beginners
- 12 Open-Source Tools**
Antenna Simulator, Component Management, Calculator, and More
- 16 Using EMI Shielding to Achieve Electromagnetic Compatibility Compliance**
- 22 HDI in the Middle**
A New Cost-Effective PCB Pooling Service for Tiny BGAs
- 24 The Ultimate Tool for Every Electronics Enthusiast**
Unlock Endless Possibilities with Red Pitaya and 1,000+ Click Boards™
- 26 Peculiar Parts**
Unusual ICs
- 28 Infographics: Prototyping & Production**
- 30 Andonstar AD409 Pro-ES HDMI Digital Microscope**
It's Tall and Has an Endoscope

C. J. Abate
Content Director, *Elektor*

More Prototyping and Production

Welcome to the November/December Bonus Edition of *ElektorMag*! As we wrap up 2024, we're excited to offer this digital bonus issue packed with extra content to inspire and inform our global electronics community. This edition features a variety of articles, each crafted to engage serious electronics makers, students, and professional engineers alike.

Inside, you'll find a deep dive into creating an ESP32 project with PlatformIO, a powerful development environment that streamlines embedded programming and brings out the best in IoT design. We also explore the growing world of open-source tools, from antenna simulators to essential component management and calculation utilities, making it easier than ever to start a new project. For those interested in benchtop tools, we review the Andonstar AD409 Pro-ES HDMI Digital Microscope, a versatile tool perfect for close-up inspection of your latest creations.

Whether you're in search of new design insights, practical tools, or the latest tech reviews, this bonus edition has something for everyone. Happy reading, and here's to closing the year with inspiration and innovation!



The
November/
December 2024
edition of *ElektorMag*
is available at
newsstands and in
the Elektor Store.

The Team

International Editor-in-Chief: Jens Nickel | **Content Director:** C. J. Abate | **International Editorial Staff:** Asma Adhimi, Roberto Armani, Eric Bogers, Jan Buiting, Stuart Cording, Rolf Gerstendorf (RG), Ton Giesberts, Saad Imtiaz, Alina Neacsu, Dr. Thomas Scherer, Jean-Francois Simon, Clemens Valens, Brian Tristram Williams | **Regular Contributors:** David Ashton, Tam Hanna, Ilse Joostens, Prof. Dr. Martin Ossmann, Alfred Rosenkränzer | **Graphic Design & Prepress:** Harmen Heida, Sylvia Sopamena, Patrick Wielders | **Publisher:** Erik Jansen | **Technical questions:** editor@elektor.com

COLOPHON

Elektor November/December 2024 Bonus Edition

Elektor Magazine is published 8 times a year by
Elektor International Media b.v.
PO Box 11, 6114 ZG Susteren, The Netherlands

Phone: +31 46 4389444

elektor.com | elektormagazine.com

For all your questions
service@elektor.com

Become a Member
elektormagazine.com/membership

Advertising & Sponsoring
Büsa Kas
Tel. +49 (0)241 95509178
busra.kas@elektor.com
elektormagazine.com/advertising

Copyright Notice

© Elektor International Media b.v. 2024

The circuits described in this magazine are for domestic and educational use only. All drawings, photographs, printed circuit board layouts, programmed integrated circuits, digital data carriers, and article texts published in our books and magazines (other than third-party advertisements) are copyright Elektor International Media b.v. and may not be reproduced or transmitted in any form or by any means, including photocopying, scanning and recording, in whole or in part without prior written permission from the Publisher. Such written permission must also be obtained before any part of this publication is stored in a retrieval system of any nature. Patent protection may exist in respect of circuits, devices, components etc. described in this magazine. The Publisher does not accept responsibility for failing to identify such patent(s) or other protection. The Publisher disclaims any

responsibility for the safe and proper function of reader-assembled projects based upon or from schematics, descriptions or information published in or in relation with Elektor magazine.

Print

Senefelder Misset, Mercuriusstraat 35,
7006 RK Doetinchem, The Netherlands

Distribution

IPS Group, Carl-Zeiss-Straße 5
53340 Meckenheim, Germany
Phone: +49 2225 88010



Creating an ESP32 Project With

An Introductory
Guide for Beginners



By **Riccardo Medda (Italy)**

Using PlatformIO with Visual Studio Code offers a powerful, flexible, and easy-to-use environment for microcontroller firmware development. The combination of ease of configuration, broad platform support, advanced development tools, and a large community makes this setup an excellent choice for those just starting out in the field of embedded programming. This article describes an example of integrating PlatformIO and VSC to create a design for reading humidity and temperature values with a digital sensor and an ESP32 module.

PlatformIO is an open-source integrated development environment (IDE) that is increasingly used in the hobby but also, and more importantly, in the professional field. An integrated development environment is software that provides developers with a comprehensive tool for writing, testing software code and debugging.

An IDE integrates several essential tools and features to simplify the software development process, improve productivity, and provide a consistent environment for the entire project lifecycle. It usually includes:

- An advanced text editor that supports the syntax of the programming language being used, with features such as syntax highlighting, auto-completion and indentation.
- Tools for compiling source code into executable machine language.
- A built-in debugger to detect and correct errors in the code during program execution.
- A system that facilitates the addition, management and updating of libraries and project dependencies.
- A controlled execution environment for testing the software under development.
- Systems for integration with version control tools (such as SVN, Git, Mercurial etc.), project management features, and an easy and intuitive user interface.

A popular IDE that is widely used is, for example, Visual Studio Code (VSC).

Actually, PlatformIO is not a true stand-alone IDE, but operates as a plugin (i.e., an add-on software) that can be integrated into various development environments, including Visual Studio Code (VSC), Atom, and Eclipse. Currently, Visual Studio Code is the main IDE supported by PlatformIO, probably also the one most chosen by professional developers.

By integrating PlatformIO into Visual Studio Code, developers can benefit from several features; in fact, PlatformIO is designed to simplify and improve the process of microcontroller firmware development. It supports a multitude

The ESP32 Module

ESP32 is a low-power microcontroller developed by Espressif Systems, known for its versatility and computational power. Based on Tensilica's Xtensa LX6 architecture, the ESP32 integrates several advanced features that make it ideal for a wide range of applications in Internet of Things (IoT) and embedded computing.

Salient technical features of the ESP32 include:

Dual-Core architecture: the ESP32 features two Xtensa LX6 cores, which enable parallel operations and improve overall system performance.

High clock frequency: with clock frequencies of up to 240 MHz, ESP32 offers high processing power to handle complex applications.

Wireless connection: integrated with Wi-Fi and Bluetooth connectivity, enabling wireless communication with other devices and networks effortlessly.

Built-in flash memory: ESP32 has memory, providing enough space for firmware and data loading.

Numerous and varied I/O peripherals, such as GPIO, UART, I²C, SPI and PWM ports, allowing easy interaction with other devices. **Signal processing unit (DSP):** ESP32 is equipped with a DSP that enhances processing capabilities for audio and signal processing applications.

Low-Power Mode: supports low-power modes to extend battery life in battery-powered devices (the so-called "deepsleep").

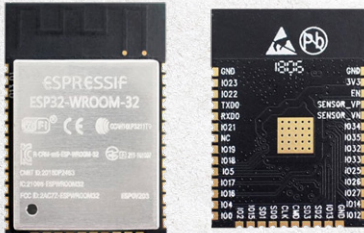

Figure A

Open-Source Development Environment: Espressif supports an open-source development environment through the use of frameworks such as Arduino and PlatformIO, simplifying the programming and development process.

Security: ESP32 incorporates advanced security features, including hardware encryption, making it suitable for projects that require a higher level of protection.

Because of these features, ESP32 is widely used to develop IoT projects, smart sensors, home automation devices and more. ESP32 is a processor that requires, at least for our purposes, an additional electronic part whose function is to provide it with the proper power supply and to interface it to a USB port on a computer, so that it can be programmed (i.e., transfer to its internal memory the firmware that will be written and compiled on PlatformIO) and to communicate with it via the serial port (on PlatformIO's Serial Monitor console).

As can be seen from **Figure A**, it cannot be used right away as is. For this purpose, there are small boards called NodeMCU that include, in addition to the ESP32 microprocessor, the aforementioned electronics. Such boards have connectors that allow them to be connected to the external environment (sensors, actuators and various devices).

This guide has been based on the NodeMCU ESP32 device visible in **Figure B**, which clearly shows the microprocessor, boundary electronics and connectors with the external world.

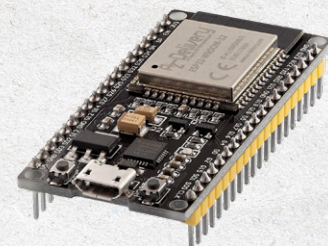

Figure B

The DHT22 Sensor

Since we will be using it in this mini-project, let us spend a few words on this sensor, which is, moreover, quite well known among insiders. The DHT22, aka AM2302, is a digital temperature and humidity sensor that offers a reliable and accurate solution for monitoring environmental conditions. This device is widely used in home automation projects, environmental monitoring, and weather applications. The DHT22 sensor uses a capacitive sensor to measure relative humidity and a thermistor to measure temperature.

Here are some of its salient technical features:

Accuracy and reliability: the DHT22 offers high accuracy in both temperature and humidity measurement.

Wide measuring range: the sensor can detect temperatures in the range of -40°C to +80°C and relative humidity in the range 0...100%.

Digital signal: the DHT22 directly transmits digital signals through a single pin, simplifying interfacing with microcontrollers such as Arduino or ESP32, which then do not have to acquire and digitize an analog signal.

Fast response time: the sensor is known for its fast response time of about 2 seconds.

High resolution: it provides data with a resolution of 0.1°C for temperature and 0.1% for humidity, allowing detailed accuracy in measurements.

High noise immunity: due to its capacitive measurement technology, the sensor is relatively immune to external interference.

Interfacing with the DHT22 is generally simple, requiring only a microcontroller and a dedicated library.

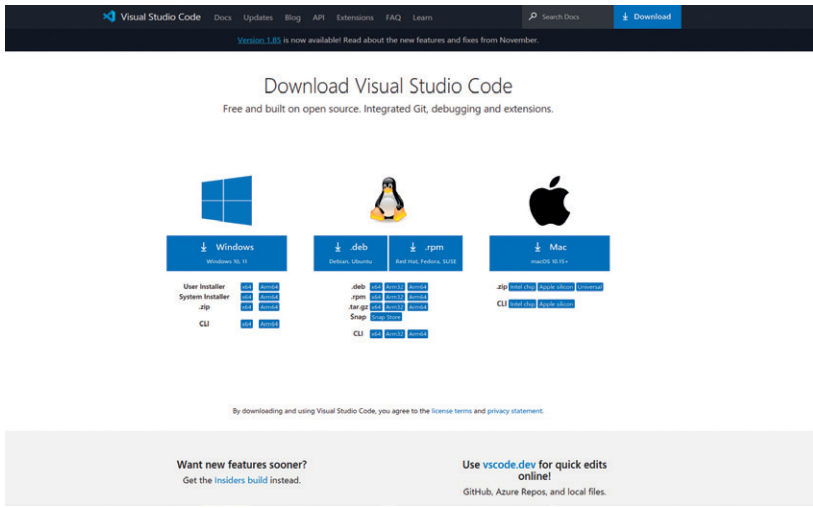

▲
Figure 1: Visual Studio Code download page. (Source for all images, unless otherwise indicated: Visual Studio Code, <https://code.visualstudio.com/>)

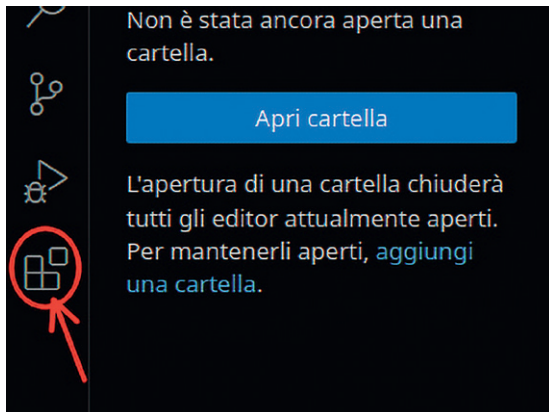

▶
Figure 2: The Visual Studio Code (VSC) button for searching plugins (Apri cartella = Open folder).

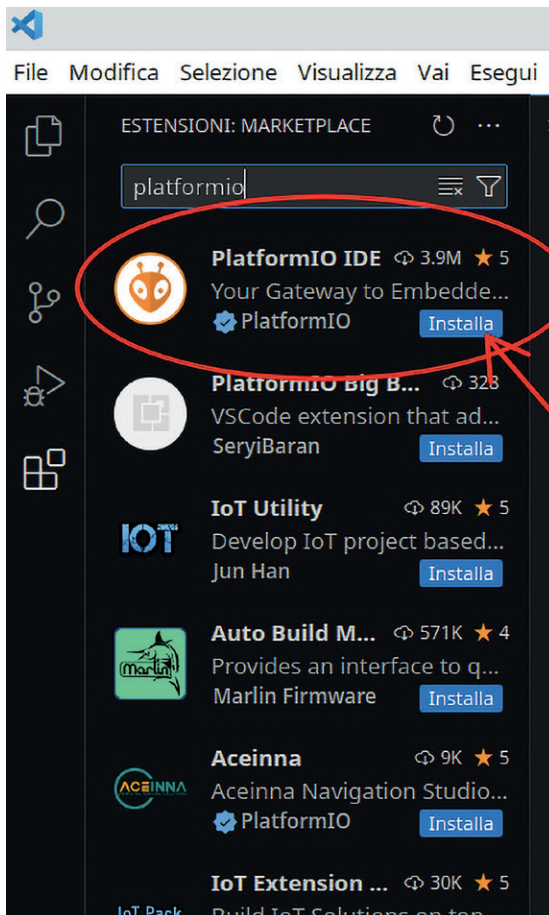

▶
Figure 3: The button for installing PlatformIO on.

of microcontrollers of various kinds, including the various versions of Arduino but also other microcontrollers and ESP8266/ESP32-based boards.

In essence, one of the distinguishing features of PlatformIO is its compatibility with various platforms, including Arduino, Espressif IoT Development Framework (ESP-IDF) and many others. This allows developers to choose the platform best suited to their needs, while using (which is of no small importance) always the same IDE.

It supports several programming language options, such as C, C++, Python and is compatible with libraries already made for Arduino. PlatformIO greatly simplifies the management of project dependencies and the various versions of libraries (both self-created and third-party) that can be included, and offers advanced compilation tools. Thus, developers can easily incorporate external libraries into their projects without having to worry about installation details.

Furthermore, PlatformIO supports library version management, making the development process more robust (as well as simple). The IDE offers comprehensive support for debugging and provides advanced tools for device monitoring and control during firmware execution. Ultimately, PlatformIO offers a unified, flexible, intuitive, and relatively easy-to-master environment that simplifies the development process and contributes to more efficient project management.

In this guide, we will see how to create and manage a PlatformIO-based project specifically for the ESP32 microcontroller, which will be connected to a DHT22 sensor to detect instantaneous ambient temperature and humidity values and display them on the PlatformIO console.

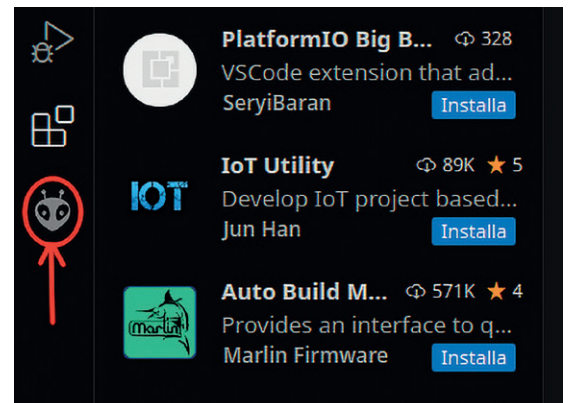

Figure 4: The icon of newly installed PlatformIO.

Installation of Visual Studio Code and PlatformIO

As previously mentioned, PlatformIO is a plugin to the Visual Studio Code IDE, so the first step is to install that IDE. The direct link to the download page can be found at [1]. As can be seen from **Figure 1**, such software is available for major operating systems (Windows, various distributions of Linux, macOS). Once we have downloaded the appropriate file for our own OS, we install it.

Whichever version is chosen, a welcome page will appear when the program starts. Closing it will bring up the main page of the IDE on the left column of which buttons appear (including the one marked in red in **Figure 2**). That is used to search for and install the plugins (aka extensions) desired on VSC. By clicking on it, the search window on the left column opens.

To find any plugin, simply type its name on the rectangular box at the top left. Typing *platformio* will bring up the plugin in the list, so all we have to do is click on the *Install* button of the PlatformIO plugin as shown in **Figure 3**. In a few minutes, it will be installed, and its presence will be indicated by the small new icon on the left column, as visible in the image on **Figure 4**. Now, PlatformIO is installed and ready to be used.

Creating the Project on PlatformIO

First, once the VSC is started, we need to click on the *PlatformIO* icon. The main page will open, on which we need to click the *Create New Project* button (**Figure 5**). A new welcome page will open (**Figure 6**), where one must click the *+ New Project* button. This action will open a simple project wizard that will ask us to enter the name of the project, the platform and the framework used, as visible in **Figure 7**.

The project name can be any (e.g., *testESP32*) while the choice of board model depends on the one we have. Typing *ESP32* in the box labeled *Board* will show a list of all available ESP32-based boards. In the present case, we have chosen the *AZ-Delivery ESP-32 Dev Kit C V4* board. As Framework, we have left the *Arduino* entry unchanged. The *Location* checkbox is used to tell PlatformIO whether to use the default one as the working folder or if you want to specify a different folder. Let's leave the default one.

The result of these choices can be seen in **Figure 8**. Clicking the *Finish* button will create the project. After a few seconds, the screen visible in **Figure 9** will appear. PlatformIO shows on the left the tree structure of the project, while in the workspace it shows the *platformio.ini* file (also part of the project) that collects the project

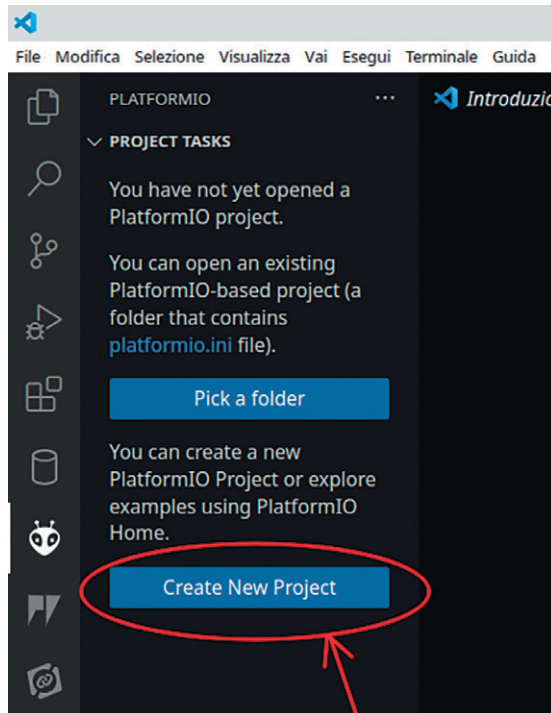

Figure 5: PlatformIO button for creating a new project.

Figure 6: PlatformIO welcome page.

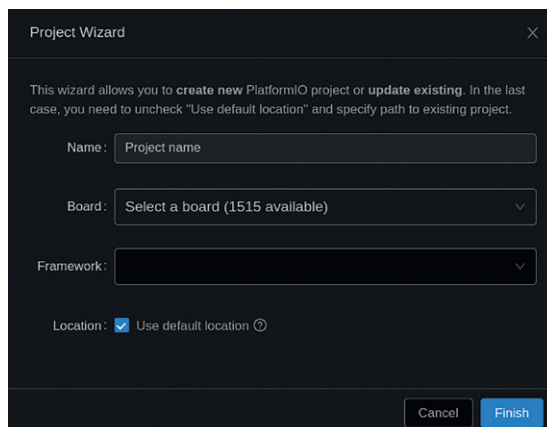
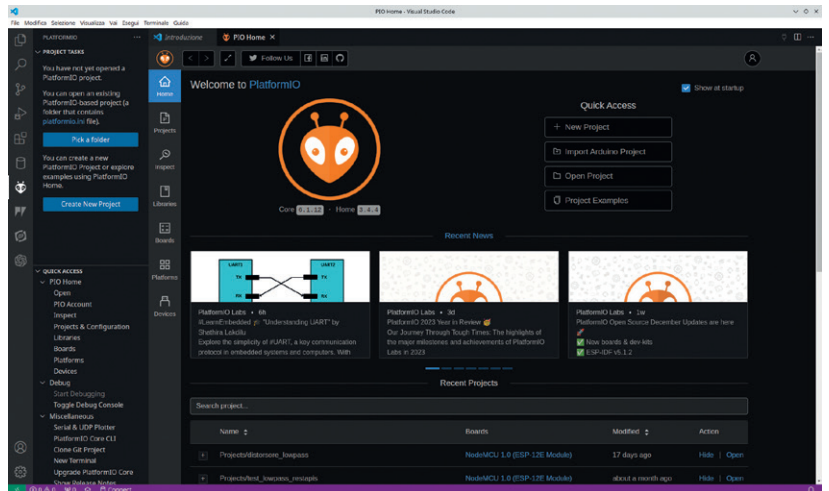

Figure 7: PlatformIO Project wizard.

settings. Currently, the settings present are the only ones provided when compiling the wizard.

In the project structure (the tree on the left) there are a few folders. One of these is called *includes* and is

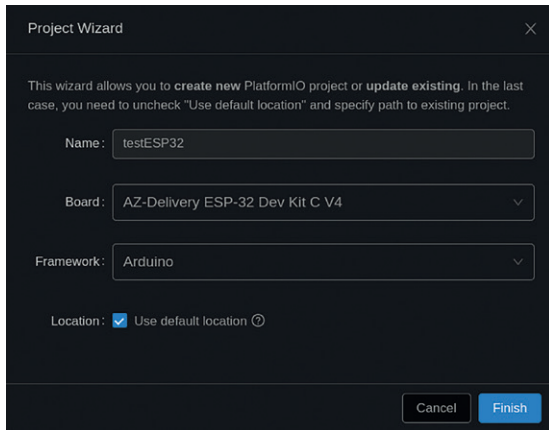

Figure 8: Project Wizard compiled.

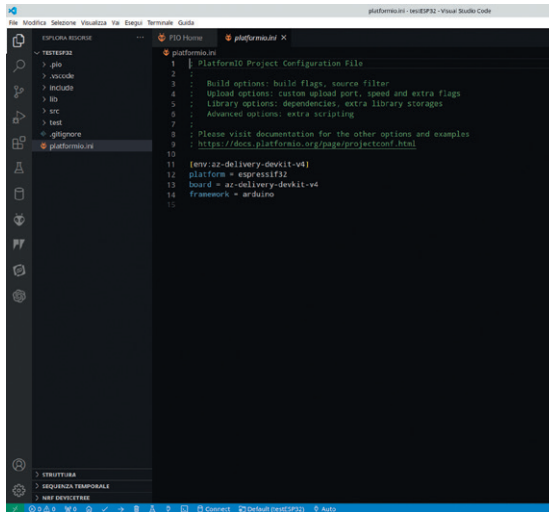

Figure 9: Project created.

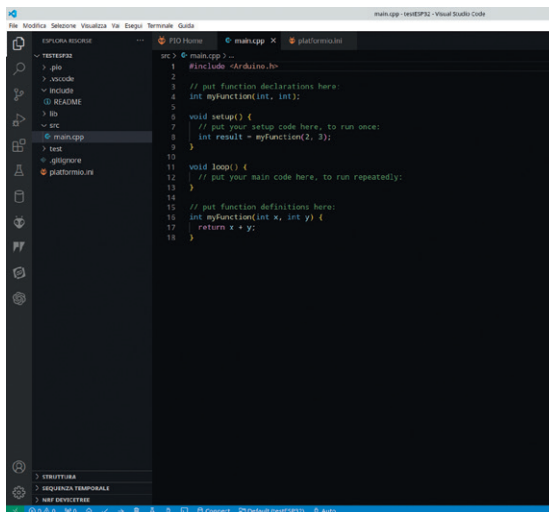

Figure 10: The default main.cpp file.

currently empty. Its function is to collect any files to be included in the project (typically *.h* files). Another folder is called *src* and contains the file *main.cpp* which will be the main file of the sketch, that is, the one where the program is to be written.

Figure 10 shows the contents of that file. Notice that the two main functions used in sketches for Arduino appear: *setup* and *loop*. In the file system, the project will appear organized as in Figure 11.

Note: The operating system used to make this guide is Linux. It is possible that on Windows and macOS the organization of the files on the file system will be different. But the interface of PlatformIO will always be the same, regardless of the operating system used.

Adding Libraries to the Project

Adding libraries to the project is a fairly simple operation. Suppose we want to add the *DHT sensor library for ESP* (which is used to read the data transmitted by the DHT22 temperature and humidity sensor). First, we need to go to the left column of the IDE and click on the *PlatformIO* icon. This will open the main page of PlatformIO, where the *QUICK ACCESS* section becomes available. One of its entries is *Libraries*. Clicking it will open the libraries search window, visible in Figure 12.

By typing *DHT22* in the search box, several results will appear. The choice falls on the *DHT sensor library for ESPx* by Bernd Giesecke, as visible in Figure 13. Clicking on it will open the library page (Figure 14).

To install the library, simply click the *Add to Project* button, select in the next wizard the project of interest (in our case *testESP32*) as shown in Figure 15 and click the *Add* button. PlatformIO will automatically download the library within the project folder. It will also add it to the *platformio.ini* configuration file, as shown in Figure 16.

This is the standard procedure for adding a library to the project. An alternative procedure is to directly edit the *platformio.ini* file by adding the entry *lib_deps* = followed by the list of libraries to be added. In our case, it would have been sufficient to add the line:

```
lib_deps=beegee-tokyo/DHT sensor library for ESPx@^1.19
```

In conclusion, libraries can be added with the search page or, if you know the name, with the path, directly to the *platformio.ini* file. To use the library just added to the project it will have to be included, for example, in the file *main.cpp*, by adding the line *#include "DHTesp.h"* immediately after the line *#include "Arduino.h"*.

On the *platformio.ini* file we also add the following lines:

```
monitor_speed = 115200
upload_speed = 921600
```

so that it appears as in Figure 17. These two commands are used, respectively, to set the speed of the serial port for communication with the computer and the speed at which the sketch is uploaded to the memory of the microcontroller.



▲ Figure 11: The project on file system.

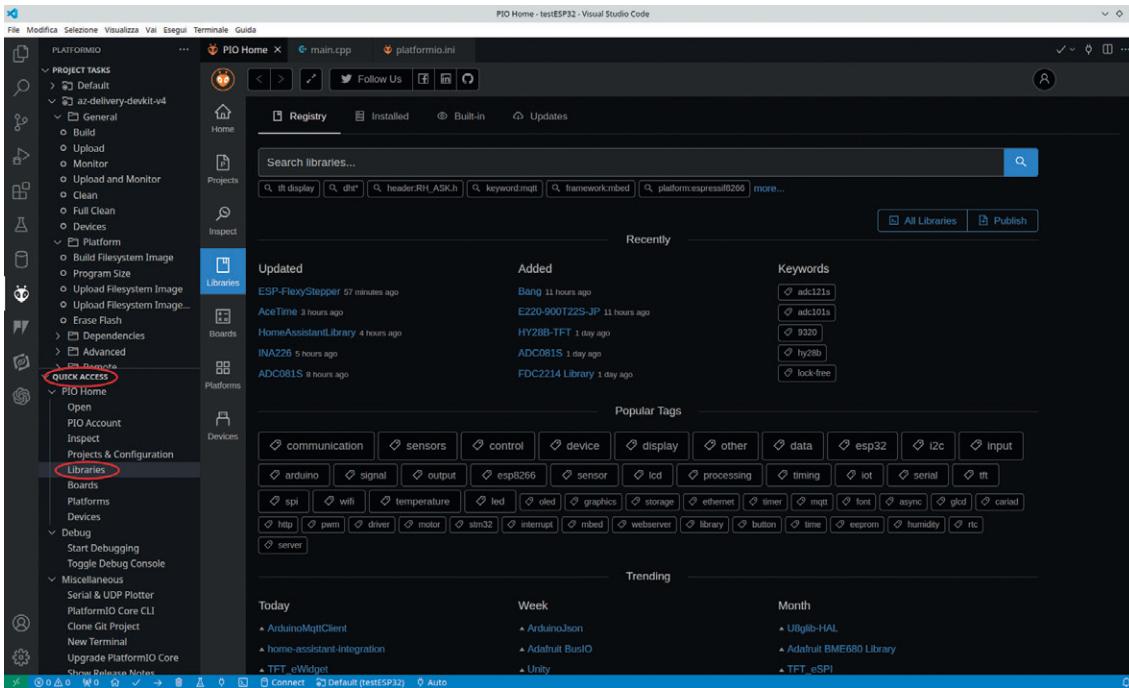

◀ Figure 12: PlatformIO library search page.

Testing the Project

To get a working example of the newly created (thus empty) project, we decided to connect the microcontroller to a DHT22 sensor, read the measured values of ambient temperature and humidity in real time, and display them through PlatformIO's Serial Monitor.

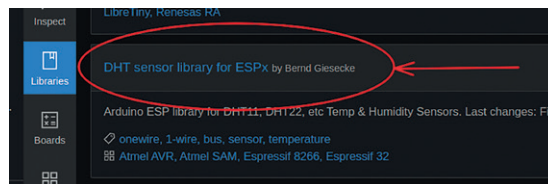

◀ Figure 13: The library chosen for sensor management.

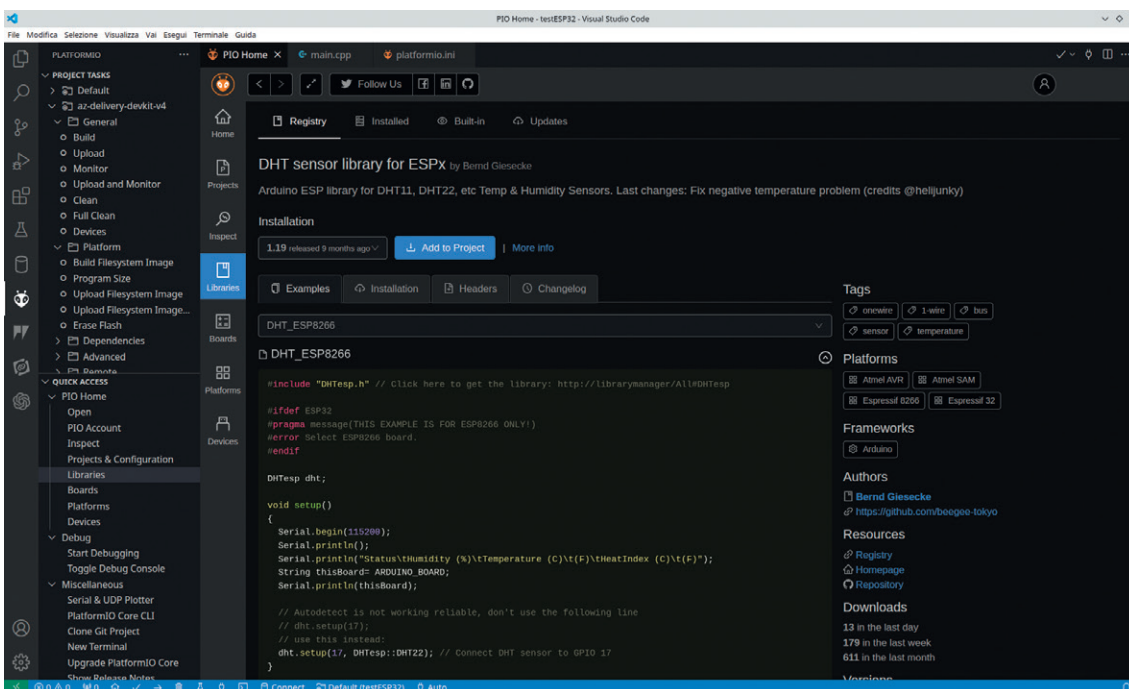

◀ Figure 14: Page of the DHT sensor library for ESPx by Bernd Giesecke.

Figure 15: Library add-on.

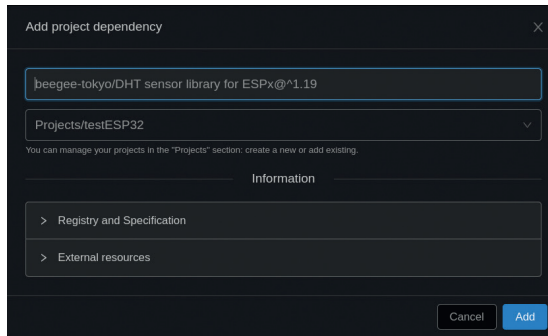

Figure 16: Platformio.ini file with the added library.

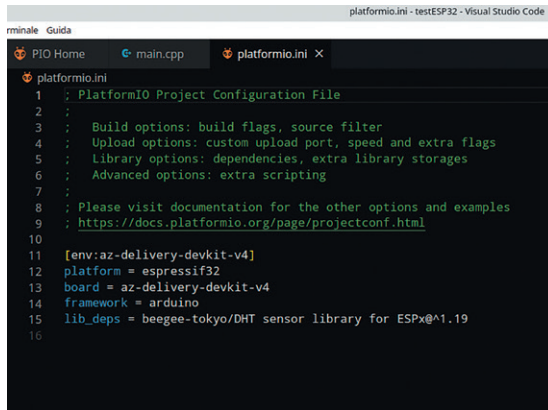

Figure 17: New version of platformio.ini file.

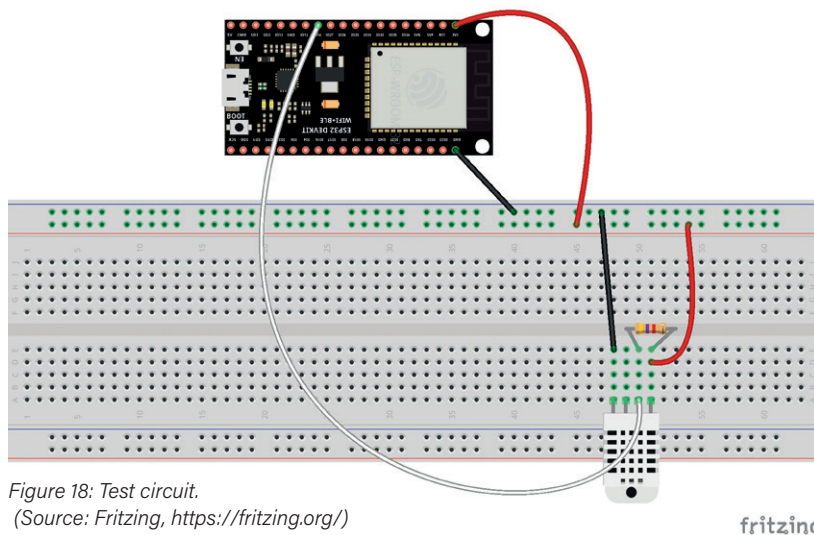
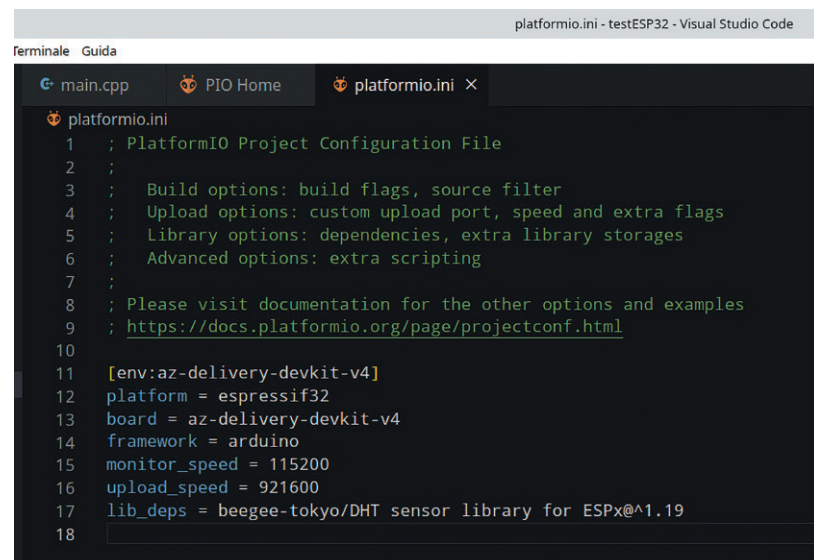

Figure 18: Test circuit. (Source: Fritzing, <https://fritzing.org/>)

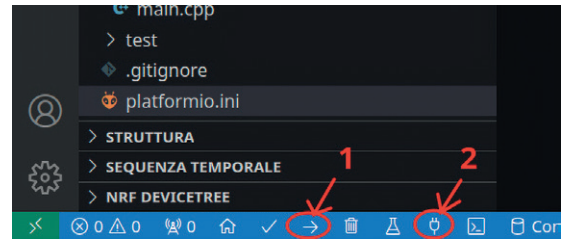

Figure 19: Compile and load sketch button and Serial Monitor activation button.

In addition to the microcontroller and sensor, we needed a 4.7 k resistor, some wires and a breadboard to make the simple circuit visible in **Figure 18**. As can be seen from the picture, unfortunately, the size of the ESP32 NodeMCU did not allow it to be placed on the breadboard, so it was left out.

The Sketch

Listing 1 is contained in the *main.cpp* file. The sketch begins with the inclusion of the necessary libraries. Next, the `dht` object of type `DHTesp`, which is used to manage the sensor, is instantiated. Then the GPIO of the ESP32 that will read the data from the sensor (in our case 14) is assigned.

Variables are defined that will contain the measured values and those that manage the timing of the measurements (in this case the readings will occur every 3 s). It would be good not to go below this value because the DHT22 takes about 2 s to make a measurement.

Next comes the `printData()` function, which reads the temperature and humidity variables and prints them to PlatformIO's Serial Monitor, giving them minimal formatting. The `setup` function initializes the serial port (through which prints to the Serial Monitor will pass) and connects GPIO 14 to the sensor.

Finally, the `loop` function detects, every `measureDelay` ms, the measurements made by the sensor and stores them in the two variables temperature and humidity. It then calls the `printData()` function to print the results. All of this is done cyclically. To load the sketch onto the board, simply click on the button indicated with the number 1 in **Figure 19**.

The sketch will first be compiled and then, if no compilation errors occur, loaded into the internal memory of the ESP32 microcontroller. To visualize the results, the Serial Monitor must be activated by clicking the button indicated with the number 2, still in **Figure 19**. **Figure 20** shows the results printed on the Serial Monitor.

Ready for Coding?

As can easily be seen, creating a project with PlatformIO and adding any libraries is all in all a fairly simple and standardized operation. PlatformIO combines ease of use with comprehensive functionalities, which have

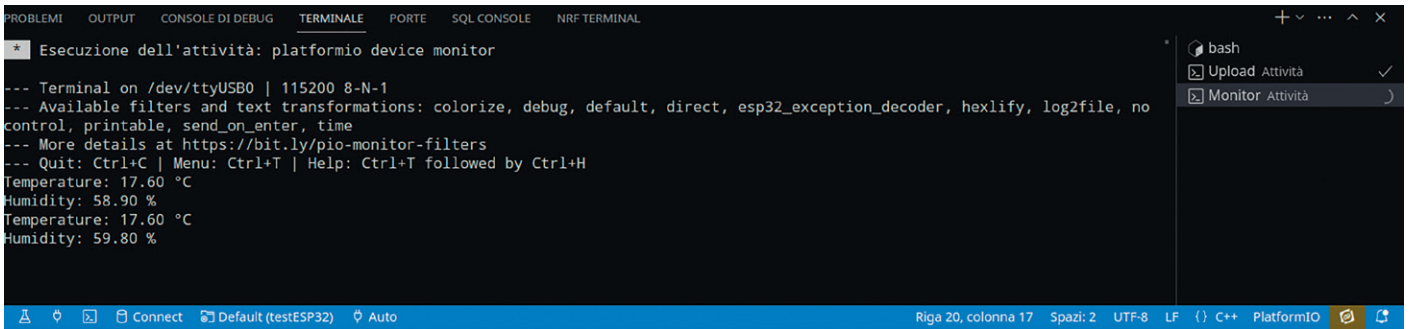

Figure 20: Printout of the results on the Serial Monitor.

not been examined here, since it is not the purpose of this guide.

Advanced library management and easy installation of dependencies further simplify the development process, allowing more focus on creating the project, rather than on configuring the environment. In addition, native integration with Arduino and its large developer community provide additional benefits, allowing access to a vast ecosystem of shared resources and solutions.

Using PlatformIO for ESP32 represents a significant step toward a more efficient, organized, scalable and professional development process. The platform provides the tools needed to explore innovative ideas, create complex designs and accelerate the development cycle, making the programming experience smoother and therefore more rewarding. ◀

240370-01



Related Products

- Joy-IT NodeMCU ESP32 Development Board
www.elektor.com/19973
- Joy-IT Sensor Kit X40
www.elektor.com/18124



Listing 1: Loop for Sensor Data Read and Printout.

```
#include <Arduino.h>
#include "DHTesp.h"

DHTesp dht;
#define DHT22_PIN 14

float temperature;
float humidity;
unsigned long measureDelay = 3000; // NOT LESS THAN 2000!!!!
unsigned long lastTimeRan;

void printData() {
  Serial.print("Temperature: ");
  Serial.print(temperature);
  Serial.println(" °C");
  Serial.print("Humidity: ");
  Serial.print(humidity);
  Serial.println(" %");
}

void setup() {
  // put your setup code here, to run once:
  Serial.begin(115200);
  // This delay gives the chance to wait for a Serial Monitor
  // without blocking if none is found
  delay(1500);
  dht.setup(DHT22_PIN, DHTesp::DHT22);
  // Connect DHT sensor to GPIO 14
}

void loop() {
  //put your main code here, to run repeatedly:
  if (millis() > lastTimeRan + measureDelay) {
    humidity = dht.getHumidity();
    temperature = dht.getTemperature();
    printData();
    lastTimeRan = millis();
  }
}
```

WEB LINKS

[1] Visual Studio Code download page: <https://code.visualstudio.com/download>

Open-Source Tools

Antenna Simulator, Component Management, Calculator, and More

By Tam Hanna (Hungary)

Open-source tools are fun — and not just because they are free. For people with an interest in software, they offer the opportunity to take a look “under the hood” of a tool that sees daily use. Here are some programs that are both open-source and useful.

Converter NOW: Convenient Unit Conversion

Problems with the use of correct units are part and parcel of international teams — while the Brit loves his Anglo-Saxon units, the continental European uses SI units. That such errors can lead to major and expensive problems is best illustrated by the loss of the MCO space probe.

Converter NOW [1], developed by Damiano Ferrari, provides a remedy — in principle, it is an ordinary unit converter which smoothly does its job, as shown in **Figures 1 and 2**. Converter NOW is also interesting from a software point of view: The product is based on Google’s cross-platform environment, Flutter. So, anyone looking for an introduction to this new system would be well advised to study the code.

A Pocket Calculator for Free

If your Android smartphone can be equipped with new apps, you can also install **Calculator N+** [2]. This is a Symja-based program [3] that emulates a powerful scientific calculator on your smartphone (**Figure 3**). When it comes to the practical use of this app, there is of course always the question of whether a hardware calculator might be more convenient to use — at the end of the day, it’s a matter of taste.

Component Management

Once it was a common job in many developer shops: a dedicated component manager who took care of the inventory and provi-

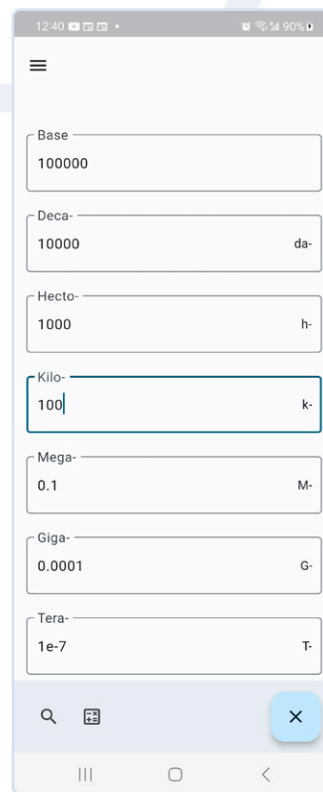

Figure 1: Converter NOW helps both in the fight with SI units...

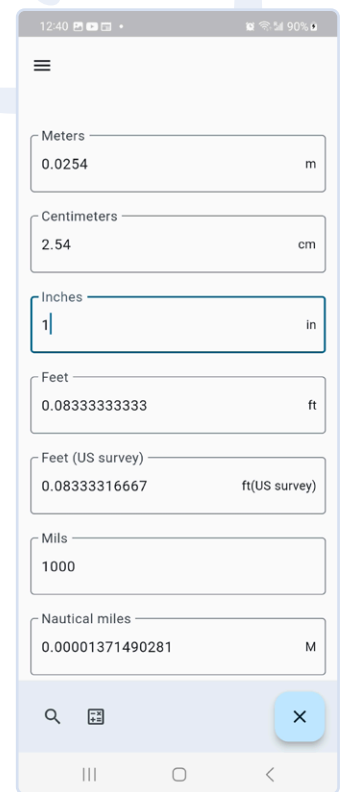

Figure 2: ...as well as in converting lengths.

sioning of the required components. Those who work alone often counter this problem by excessive use of a distributor: Every bill of materials is bought new, leftover components are put in storage, given away or thrown in the bin.

Component management solutions are a dime a dozen in the freeware and commercial space. Both **InvenTree** and **PartKeepr** are open-source — both are web applications, which makes them a bit more complicated to set up. Specifically, a web server is required, which the (various) clients then access via a web browser.

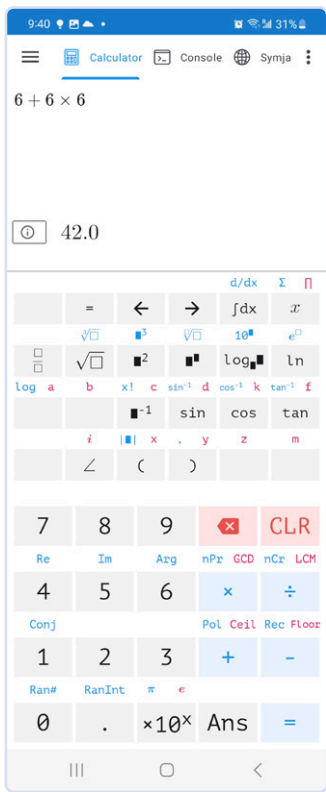

Figure 3: Any similarities to TI, Casio, etc. are purely coincidental.

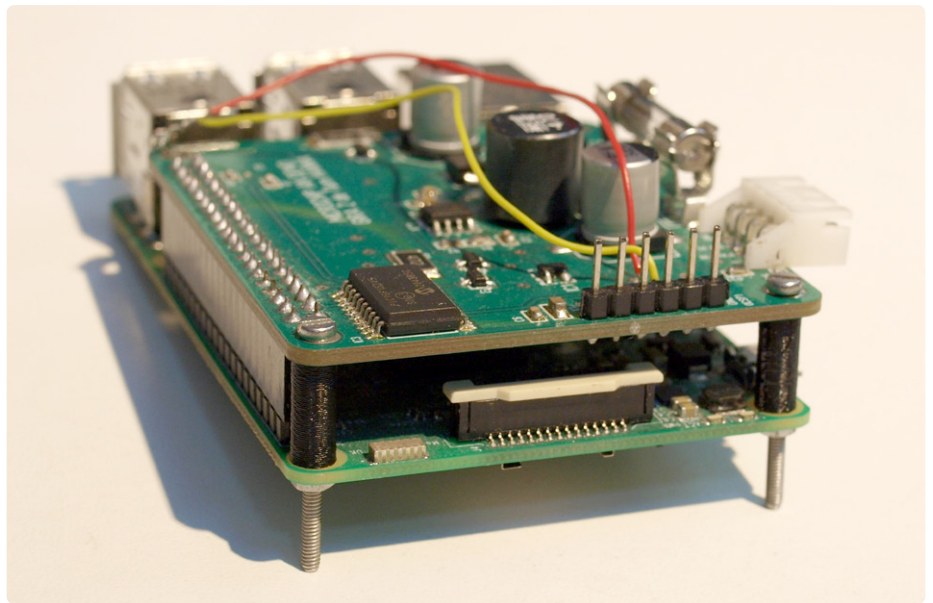

Figure 4: This decommissioned, older Raspberry Pi provides various "local services" in the author's lab.

A convenient way around this problem is to use a Raspberry Pi or similar process computer. On Thingiverse, you can find various cases that can be screwed under a desk in the lab. Once installed, the Raspberry Pi then has a discrete, space-saving home (Figure 4).

The question of whether InvenTree (Figure 5) or PartKeepr (Figure 6) is more convenient can be discussed extensively. I recommend you try the demo versions. [4, 5] Simply test both and then decide which system fits your preferred working style better.

When using either system, the effort invested should fit the situation at hand. For example, both products offer BOM management, which can be overkill, especially for smaller, prototyping-oriented companies.

Simulation Saves Working Time

Especially in the design of antennas, it is true that simulation can avoid referrals to RF hardware manufacturers. In general, the owners of the various simulation algorithms are aware of this connection, which is why antenna simulators turn out to be anything but cheap.

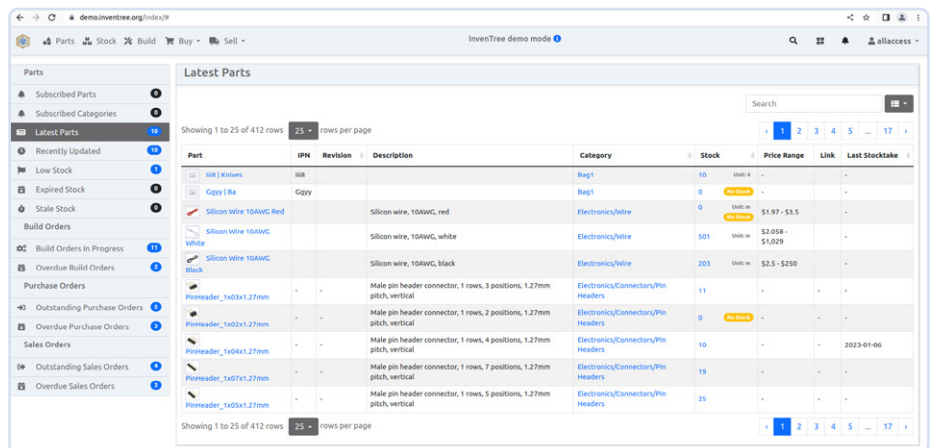

Figure 5: The differences between the GUIs of InvenTree ...

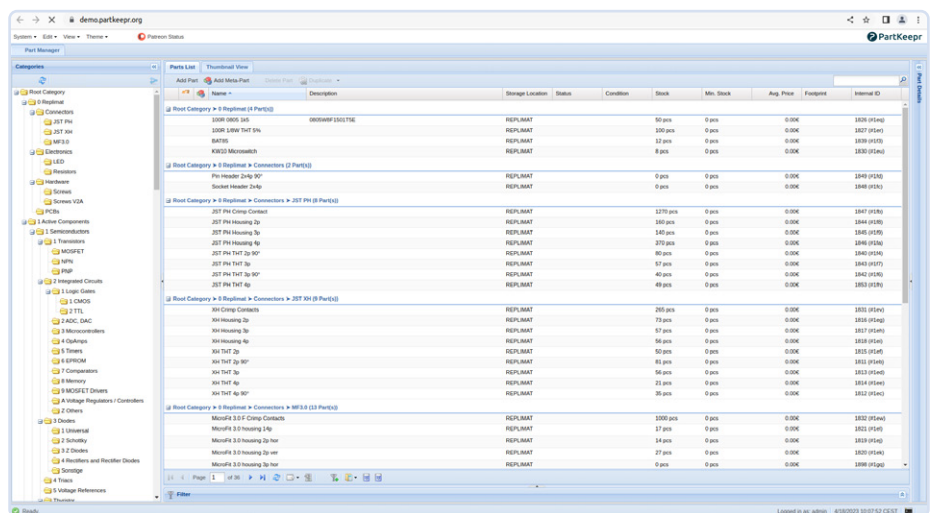

Figure 6: ... and PartKeepr are definitely significant.

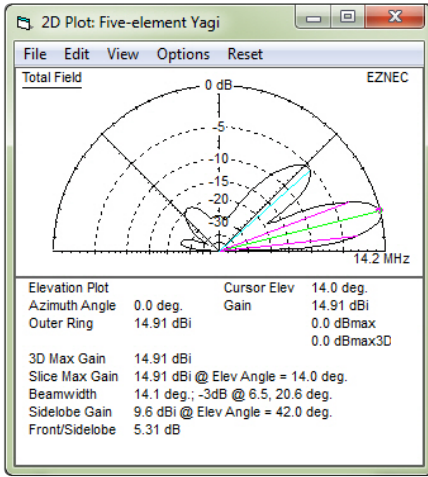

Figure 7: EZNEC facilitates the operation of NEC.

The number one open-source antenna simulator is **NEC**. Behind this term is not the Japanese electronics giant of the same name, but the abbreviation *Numerical Electromagnetics Code*. This is an antenna simulation product developed by Lawrence Livermore National Laboratory that is partially open source as of the printing of this article. Specifically, version 2 of the product is open source, while later versions must be purchased.

The popularity is due in part to the fact that **EZNEC** [6], a graphical user interface for the product, has been available free of charge for about a year (Figure 7). The American Radio Relay League (ARRL) used this program for many years in the *Antenna Book* as a “demonstration system,” so the operation of the scripting language should be at least somewhat familiar to many technicians.

With **openEMS** — a product developed within the EU — a similar simulator is available [7]. The most important argument in its favor is the possibility of assembling the modeling scripts using the widely-used Python language. Figure 8, which is taken from the documentation [8], shows an S-parameter simulation over a frequency range.

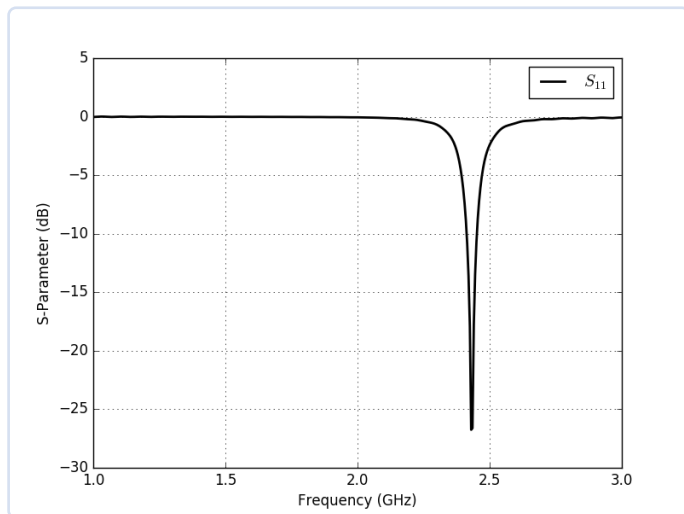

Figure 8: The graphical results of Open EMS are quite impressive (Source: [8]).

Finally, **Elmer** should be mentioned, albeit briefly (Figure 9). This is a mature tool [9] that is optimized for the solution of various problems of “finite elements.” It should be noted that its operation requires extensive training.

Bonus: OpenSCAD!

The design of housings and technical moldings in classic CAD programs is a task that especially “veteran” electronics engineers, who grew up with a pattern maker’s shop, do not easily learn at first sight. **OpenSCAD** [11] is a system that uses a “bottom-up” approach to address this. Specifically, a description language reminiscent of Python and C is used, and it compiles the objects to be generated from “geometric primitives” (Figures 10 and 11). The result of the compilation is an STL file that can be realized with various 3D printers, for example. ◀

Translated by Jörg Starkmuth — 230282-01

Questions or Comments?

If you have technical questions or comments about this article, feel free to contact the Elektor editorial team by email at editor@elektor.com.

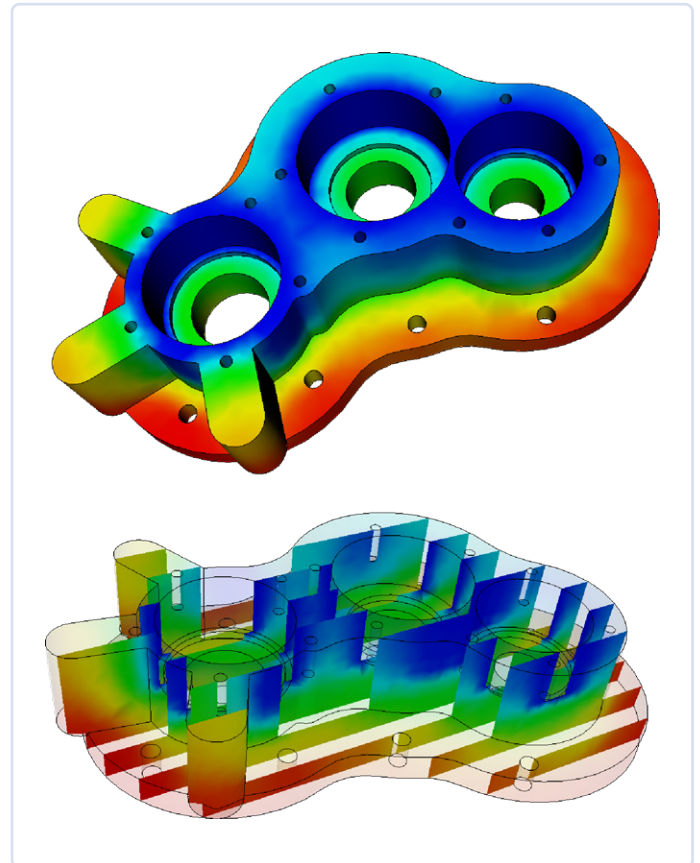

Figure 9: This object was not calculated with CATIA, but with Elmer (Source: [10]).

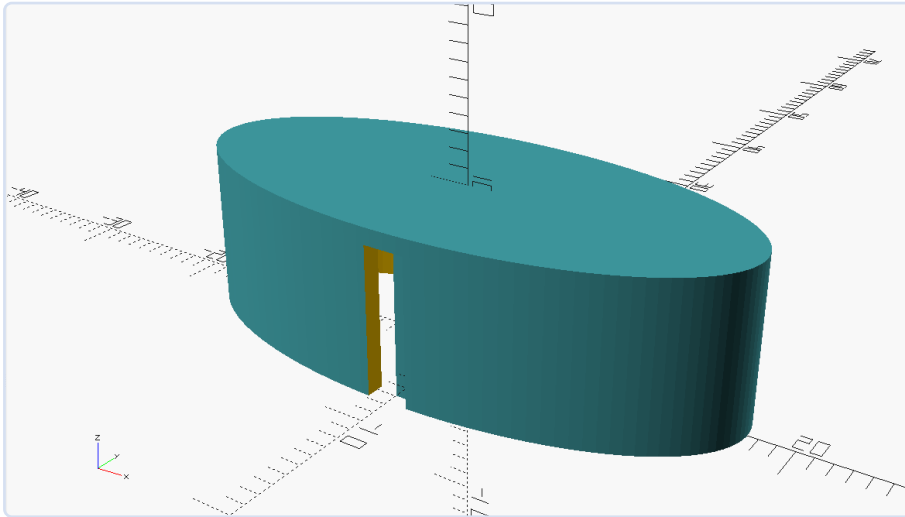

Figure 10: This replacement button for a dishwasher looks decent both from the front ...

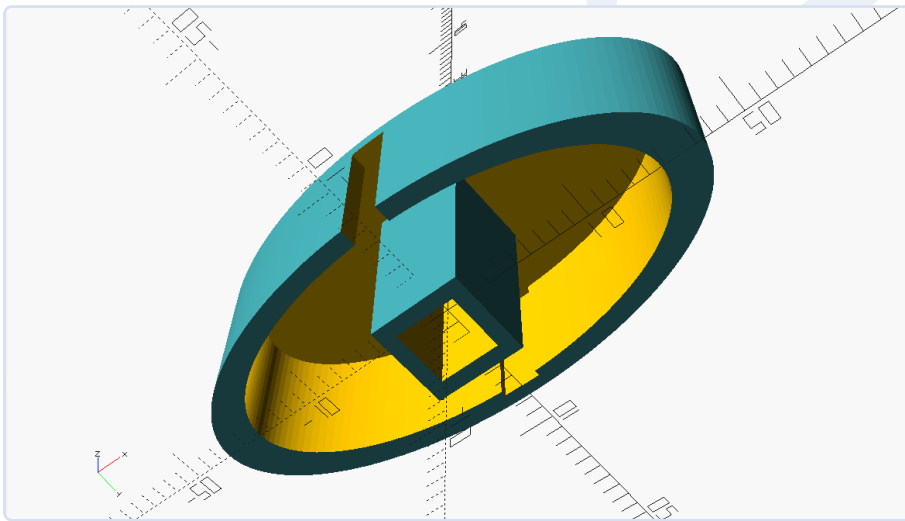
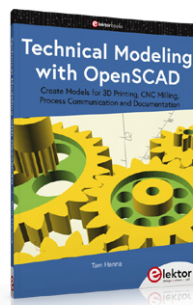

Figure 11: ... as well as from the back.



Related Products

- › T. Hanna, *Technical Modeling with OpenSCAD* (Elektor 2020)
<https://elektor.com/19418>



WEB LINKS

- [1] Converter NOW on GitHub: <https://github.com/ferraridamiano/ConverterNOW>
- [2] Calculator N+ on GitHub: <https://github.com/tranleduy2000/ncalc>
- [3] Symja library on GitHub: https://github.com/axkr/symja_android_library
- [4] InvenTree Demo: <https://inventree.org/demo>
- [5] PartKeepr Demo: <https://demo.partkeepr.org>
- [6] EZNEC Antenna Software: <https://eznec.com>
- [7] openEMS: <https://openems.de>
- [8] openEMS, documentation of the patch antenna: <https://bit.ly/43W71ak>
- [9] Elmer: <https://csc.fi/web/elmer>
- [10] Elmer, application examples: <https://csc.fi/web/elmer/application-examples>
- [11] OpenSCAD: <https://openscad.org>

Using EMI Shielding to Achieve Electromagnetic Compatibility Compliance

By Mark Patrick (Mouser Electronics)

In this article, we discuss the importance of electromagnetic interference (EMI) shielding in achieving electromagnetic compatibility (EMC) compliance, particularly in the context of modern technologies like 5G and the Internet of Things (IoT). The article also explores various EMI shielding techniques, materials, and strategies that engineers can use throughout the design process to prevent interference and ensure product reliability.

Technological advances, including the expanding rollout of 5G and the increasing reach of the Internet of Things (IoT), are leading to a greater need for electromagnetic interference (EMI) shielding. Achieving electromagnetic compatibility (EMC) compliance and reducing sources of EMI early in the design process are crucial to eliminating inefficiency, avoiding costly redesign, and preventing delays in product launch. Each design part or sub-system — from the enclosure to the module to the printed circuit board (PCB) — may incorporate EMI shielding.

A wide range of shielding options are available to engineers for every stage of the design process in almost every application, from commercial to energy infrastructure, defence to automotive. This article aims to give engineers some insight into what technological advances challenge current approaches to EMI shielding and to provide an overview of the materials on the market.

Electromagnetic Interference Is Everywhere

Electromagnetic fields are a feature of virtually every circuit. Oscillatory electric fields and magnetic flux lines (**Figure 1**) occur around the conducting path when an alter-

nating current flows along a wire or through a PCB track. These become unwanted noise or interference when these fields become induced or transferred to another circuit or wire. This unwanted noise, generally referred to as EMI, can interfere with or disrupt the other circuit's operation.

An electrostatic discharge (ESD) is another form of EMI. ESD tends to be of varying frequency, whereas EMI typically occurs constantly. Any high-voltage, short-duration (high dV/dt) transients can cause erratic operation or permanent damage to sensitive electronic systems. Most electronic systems generate EMI unintentionally, including clocks, high-speed digital switching, DC/DC converters, and wireless interfaces.

EMI emissions find their way into other circuits through either conduction or radiation. For example, small signal clocks

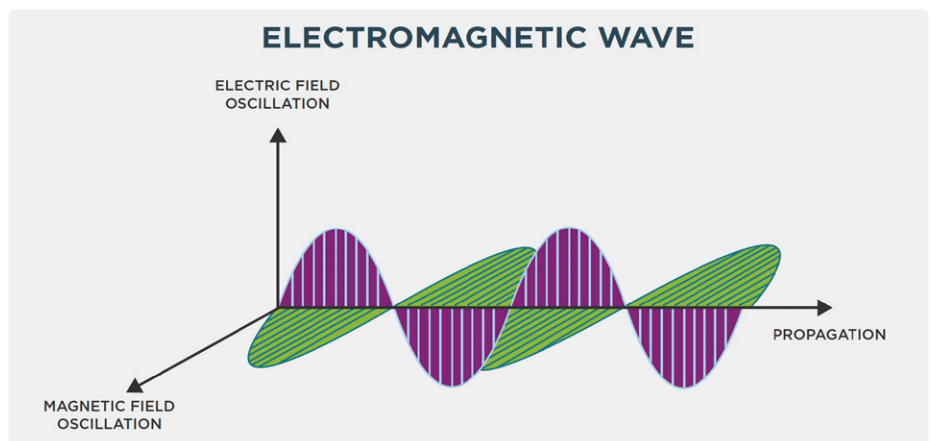

Figure 1: The magnetic and electric fields of an electromagnetic wave. (Source of all images: Kemtron Ltd, now part of TE Connectivity)

passing along a PCB trace may radiate, typically above 10 MHz, since the tracks become effective antennas. The guiding principle behind EMC is that a circuit or system is immune to EMI (**Figure 2**).

Market Dynamics and Trends

Always-on connectivity has become ubiquitous. Whether at home, on the move, work, or in our car, our society never had so many benefits of reliable and resilient communications infrastructure. The rise of the IoT and its counterpart the Industrial Internet of Things (IIoT) and the growth of cellular communications have driven our need and dependence on wireless communications, which, unfortunately, is an essential enabler and a potential EMI source. The deployment of 5G wireless infrastructures, using previously unused, ultra-high frequency wireless spectrum, further expands the possibility of EMI. Consequently, ensuring products have EMI immunity has never been more critical.

Electromagnetic Compatibility Standards

National and regional EMC standards, which typically align with internationally recognised EMC standards (**Figure 3**), provide manufacturers with specifications products must meet before sales occur. The standards stipulate the maximum emissions permitted from a product development and its immunity or susceptibility to radiated or conducted emissions. When embarking on a new design, it is recommended that design engineers consider the possibility of EMI and incorporate EMC countermeasures during the prototyping process rather than as an afterthought. An understanding of the EMI and EMC standards that apply, the likely sources of emissions, and circuit functions that may be more susceptible to EMI noise are paramount (see **Table 1**).

Achieving EMC Certification

Although an accredited EMC test facility can only perform EMC certification, there is a lot the engineering team can investigate before handing over the product to the test lab. Basic radiated and conducted emission measurements using a spectrum analyser or an EMI receiver equipped with

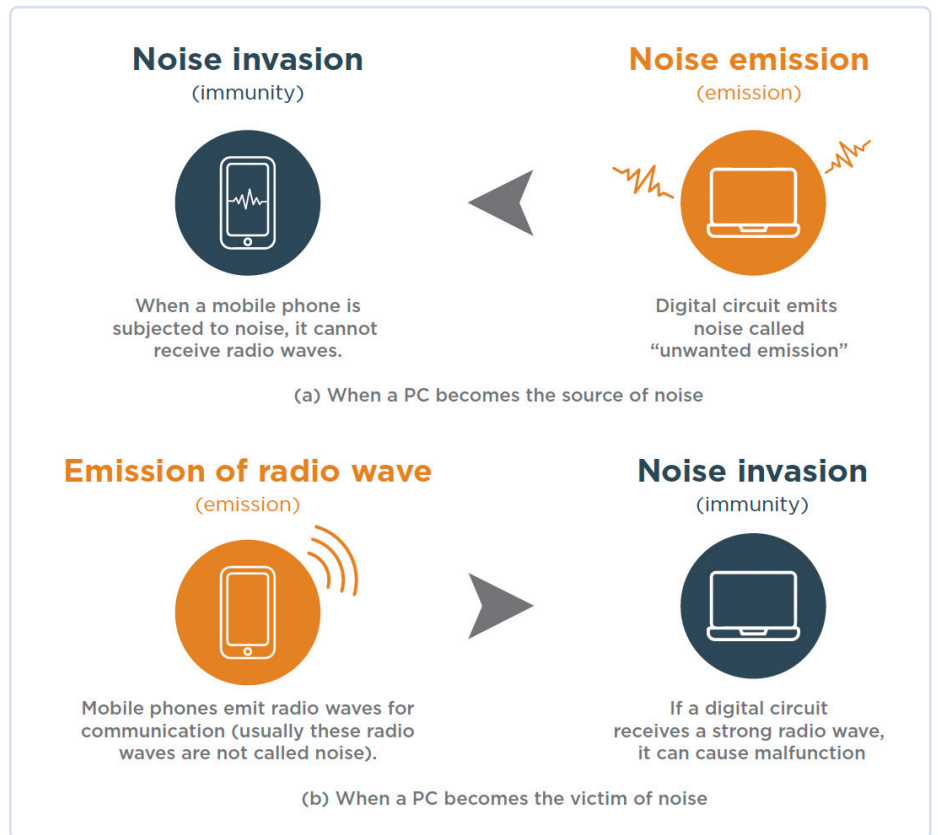

Figure 2: Immunity to EMI emissions is key to achieving EMC compliance.

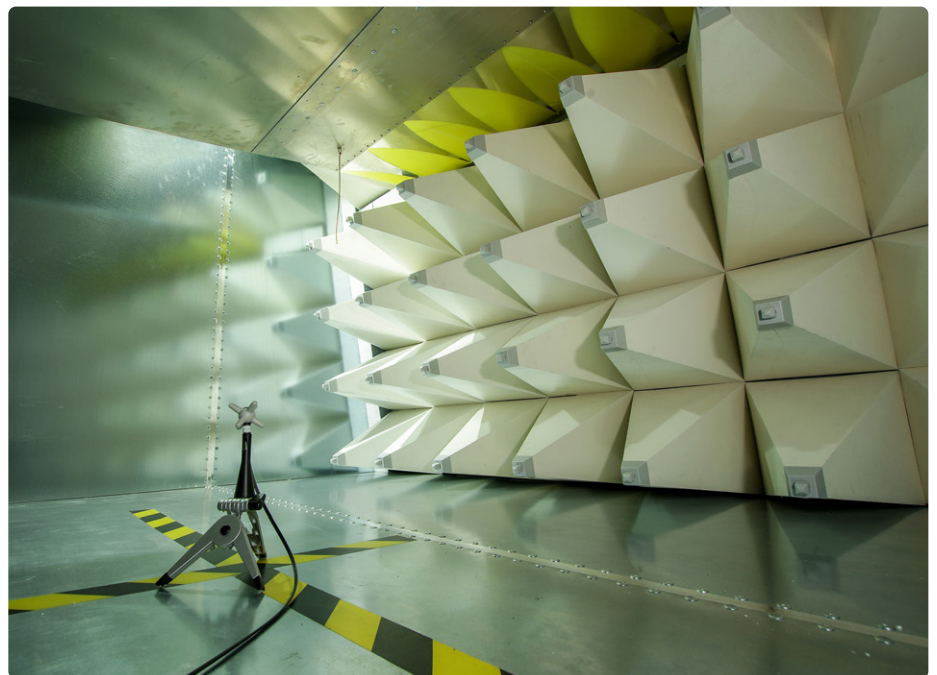

Figure 3: Pre-compliance testing of a device under test to EMI emissions.

Table 1: Popular EMI and EMC standards detailed by industry and application.

Application / Industry	EMC Standard
Aerospace, Defense and Marine equipment	DEF STAN 59-411 MIL-STD-461 MIL-STD-704 MIL-STD-1275 MIL-STD-1399
Automotive components	IEC CISPR 25 ISO 11451 ISO 11452 ISO 7637 SAE (multiple numbers)
Commercial equipment	FCC Part 15 class B IEC 61000-6-1 (generic) IEC 61000-6-3 (generic)
Industrial devices	FCC Part 15 class A IEC 61000-6-2 (generic) IEC 61000-6-4 (generic)
Medical devices	IEC 60601-1-2
Power station and substitution equipment	IEC 60000-6-5
Power station and measurement equipment (<1000 V AC, 1500 V DC)	IEC 61326-1
Switch gears and control gears (1000 V AC, 1500 V DC)	IEC 60947-1

IEC: International Electrotechnical Commission
 ISO: International Organization for Standards
 SAE: Society of Automotive Engineers
 FCC: Federal Communications Commission

(Source: Kemtron Ltd, now part of TE Connectivity)

suitable H and E field probes will indicate whether further testing or EMI countermeasures are required. These are expensive items of test equipment for a small product design team to acquire, but specialist EMI test and measurement rental companies offer a cost-effective alternative. Undertaking pre-compliance testing is highly recommended since it allows the design team to locate potential noise sources and implement EMI reduction methods such as shielding, ground planes, and decoupling. Exposing a product to EMI emissions is also important.

Levels of EMI Shielding

Reducing EMI and making circuit functions immune to EMI require a systematic approach through the product design process. This includes aspects of the PCB design, incorporating ground planes and

separating EMI noisy devices from sensitive analogue signal chains. Shielding components, functional parts, and modules offer

a practical approach for many applications based on a three-level method, focused on enclosure, module, and PCB (Figure 4).

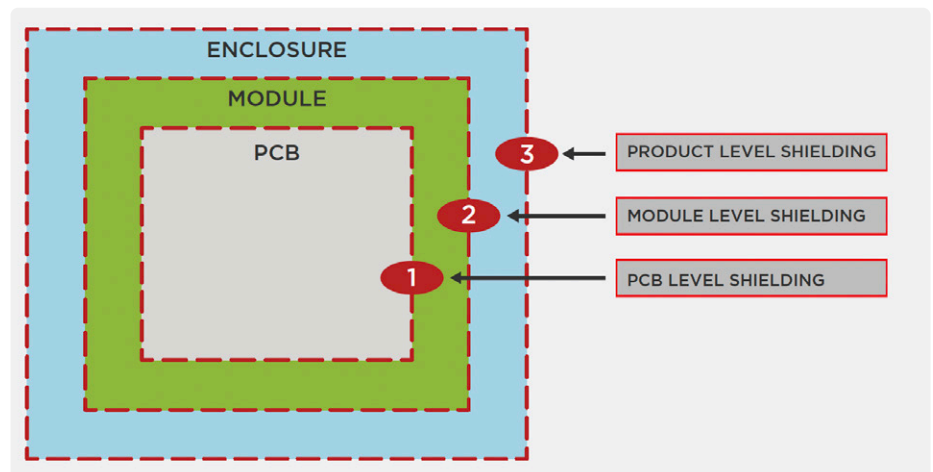
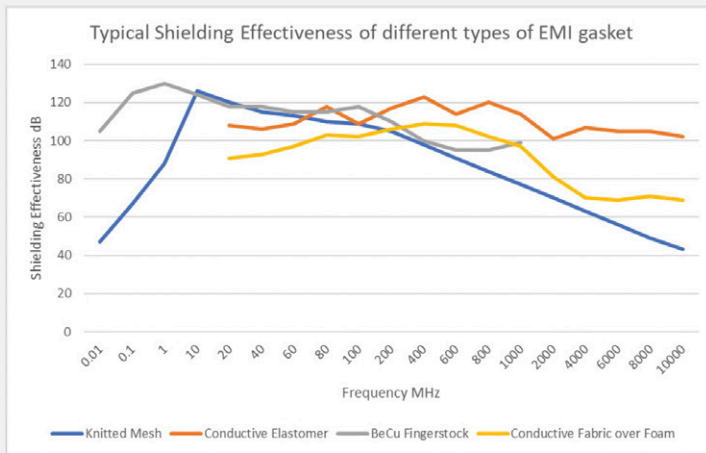

Figure 4: The three-level approach to implementing EMI shielding.

SHIELDING EFFECTIVENESS



KNITTED WIRE MESH
H field (magnetic) shielding 62dB @ 10Khz achievable. SE falls off after 1GHz

CONDUCTIVE ELASTOMERS
Shielding with wide frequency range, >100dB upto 10GHz E field.

FABRIC OVER FOAM
Shielding with wide frequency range, >100dB upto 10GHz E field.

BERYLLIUM COPPER FINGERS
Shielding with wide frequency range, >100dB upto 10GHz E field.

Figure 5: The EMI attenuation characteristics of four popular EMI shielding methods plotted against frequency.

Shielding radiated emissions works by creating a Faraday cage around the EMI source. Implementing shielding at an enclosure level reduces any potential noise source leaving or entering. However, some circuit functions may require extra levels of protection to prevent internal EMI from impacting other circuit functions. Shielding at a modular level greatly assists and is regularly used around wireless modules, DC/DC switching converters, and LCD panels. It may be necessary to provide shielding at the board level for sensitive components, such as an analogue-to-digital converter IC. Shielding also applies to any form of interconnect, so preventing radiated emissions from escaping through cable glands, plugs, and sockets should not be overlooked.

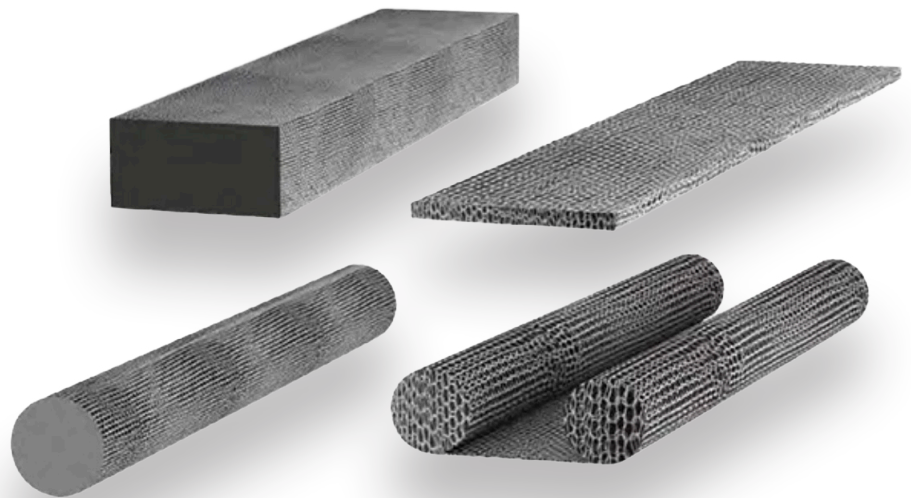

Figure 6: TE Connectivity's Kemtron knitted wire mesh gaskets are available in continuous lengths and shaped into specific sizes.

EMI Shielding Materials

Examples of EMI shielding components include knitted wire mesh gaskets, electrically conductive elastomers, conductive fabrics, and metal fingers. Each type exhibits slightly different EMI attenuation characteristics and suits specific use cases. **Figure 5** illustrates the attenuation performance of these four shielding types against frequency.

Knitted wire mesh: Using multiple layers

of wire knitted over a sponge or tube core using different mesh materials offers an effective EMI solution and galvanic compatibility. The knitted approach permits fabrication to suit complex shapes and bonding to carrier materials to create ingress protection. Mesh shielding suits various use cases, including cabinet doors, lids, and removable cover plates. Shield performance tends to reduce beyond 1 GHz unless additional

layers are incorporated. Examples include TE Connectivity's Kemtron range of knitted wire mesh gaskets (**Figure 6**), available in cut lengths or fabricated into finished gasket shapes [1].

Electrically conductive elastomers: Available in various materials and shapes, Kemtron Ltd (now part of TE Connectivity) range (**Figure 7**) offer better than 100 dB



Figure 7: Electrically conductor elastomers from Kemtron/TE Connectivity offer up to 100 dB of attenuation at 10 GHz.

attenuation up to 10 GHz [2]. Filler Materials include silver-plated aluminium and nickel-plated graphite, binder options include silicone or fluorosilicone. Popular shapes include sheets, flat gaskets and O-rings. “Jam nut” O-ring seals are designed explicitly for RF EMI shielding and are available for the most popular connector formats [3].

Honeycomb air vents: For applications where forced air cooling uses a fan, the fan aperture offers a direct path for noise to exit an otherwise EMI-sealed enclosure. To prevent this, using a honeycomb air vent, such as the Kemtron/TE Connectivity

line-up, offers enhanced EMI performance while permitting adequate airflow through its laminated, single-layer aluminium foil honeycomb cell construction. The vents are available in all popular fan sizes, from 40 mm to 120 mm [4].

Improve EMI Immunity

EMI from unwanted noise emissions from equipment disrupts reliable system operation. Achieving EMC is a regulatory requirement and a necessity to avoid erratic system behaviour. This short article highlighted some shielding methods engineers could implement to improve EMI immunity. ◀

240531-01



About the Author

As Mouser Electronics' Director of Technical Content for EMEA, Mark Patrick is responsible for creating and circulating technical content within the region — content that is key to Mouser's strategy to support, inform, and inspire its engineering audience. Before leading Technical Content, Mark was part of Mouser's EMEA Supplier Marketing team and played a vital role in establishing and developing relationships with key manufacturing partners. Mark's previous experience encompasses hands-on engineering roles, technical support, semiconductor technical sales, and various marketing positions. A “hands-on” engineer at heart, Mark holds a first-class Honors Degree in Electronics Engineering from Coventry University. He is passionate about vintage synthesizers and British motorcycles, and thinks nothing of servicing or repairing either.

WEB LINKS

- [1] Knitted Wire Mesh Gaskets: <https://www.mouser.de/new/te-connectivity/te-kemtron-knitted-wire-mesh-gaskets/>
- [2] EMI Connector Gaskets: <https://www.mouser.de/new/te-connectivity/te-kemtron-emi-connector-gaskets/>
- [3] Jam Nut Seals: <https://www.mouser.de/new/te-connectivity/te-kemtron-jam-nut-seals/>
- [4] Aluminum Honeycomb Air Vents: <https://www.mouser.de/new/te-connectivity/te-kemtron-honeycomb-air-vents/>

What's Your Opinion?

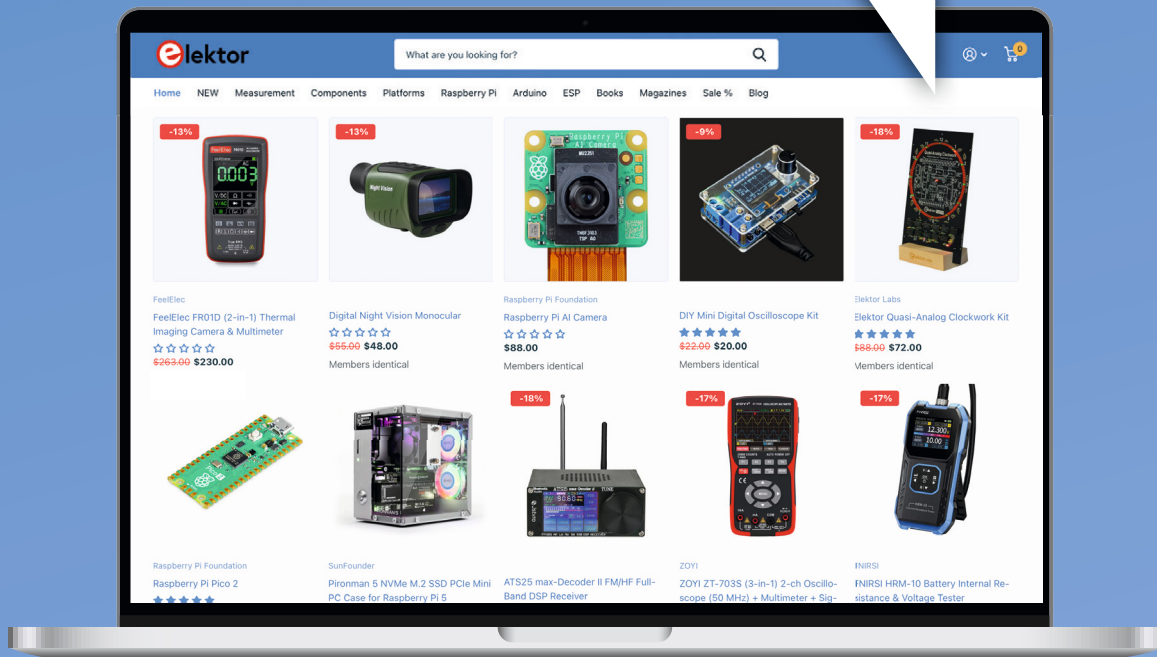

At Elektor, we offer more than just electronics – we create an experience of quality products and exceptional customer care, backed by the passion of our community.

Share your opinion on
www.elektor.com/pages/customer-reviews



★★★★★

Thanks for the great educational value.

★★★★★

You have been doing great. Keep it up.

★★★★★

I Love Elektor!

HDI in the Middle

A New Cost-Effective PCB Pooling Service for Tiny BGAs

Contributed by Eurocircuits

Sometimes there's a part that we really want to use, but it's only available in a fine-pitch BGA package — using it will tip our design over the 'standard PCB technology' line into HDI territory. HDI technically means *high-density interconnect*, and practically means that we're able to design with smaller clearances and thinner tracks. And, we're able to use 'microvias': vias with smaller pads and smaller hole diameters than what is normally possible with mechanical drilling.

HDI enables miniaturization, which is great, but it may be annoying if it is 'forced' on us from a single tiny component onto the entire board, which then becomes prohibitively expensive. At Eurocircuits, we have the solution 'in the middle' that can help our customers deal with both the annoyance and the cost. Our HDI pool (**Figure 1**), an 8-layer buildup, keeps the 'standard technology' pattern classifications as they are, and adds microvias between layers 1–2 and 2–3

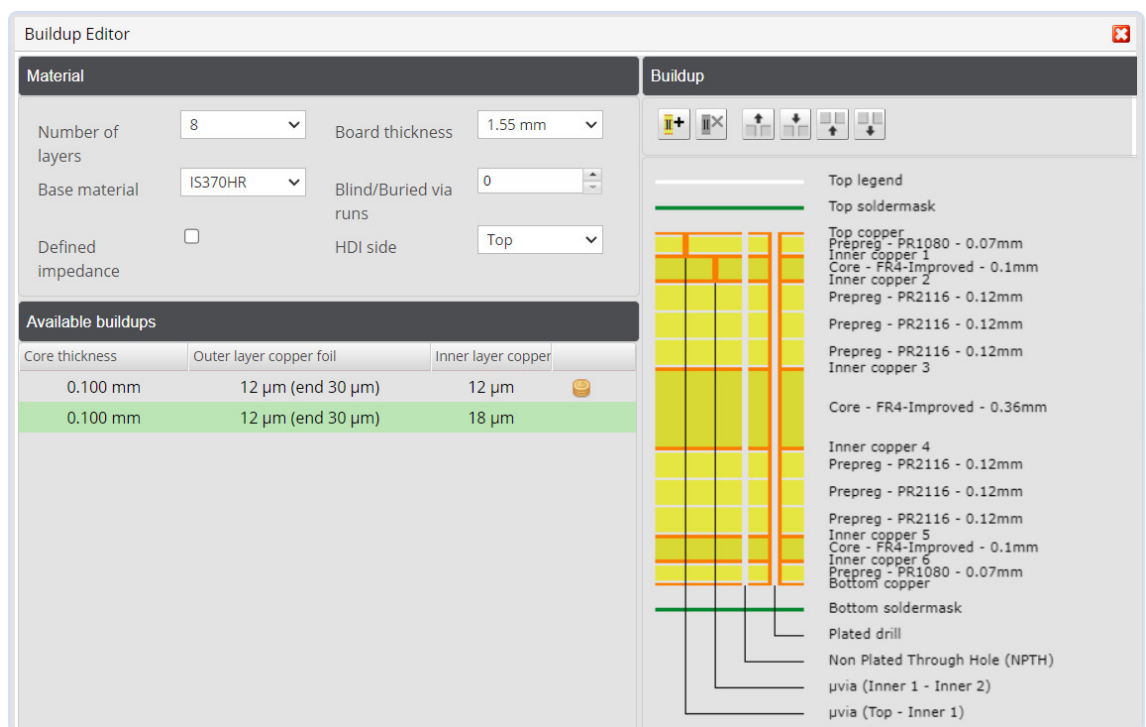

Figure 1: Our 8-layer HDI pool buildup.

Pattern and hole size classification (µm)

Revision 20242808-1

Pattern classification

		7	8	9
Copper clearance, any layer	≥	125	100	90
Pad diameter, outer layers Add this value to N/PTH diameter	≥	+350	+300	+300
Pad diameter, inner layers Add this value to N/PTH diameter	≥	+350	+350	+300
Clearance from PTH, inner layers From hole edge	≥	250	250	250
Clearance from NPTH, inner layers From hole edge	≥	200	200	200
HDI microvia pad diameter Available only for layers 1-2 and 2-3	≥	280	230	210
HDI microvia diameter Available only for layers 1-2 and 2-3	=	100	100	100

Hole diameter classification

		A	B	C	D	E
Plated through-hole (PTH) diameter	≥	500	350	250	150	100
Non-plated through-hole (NPTH) diameter	≥	600	450	350	250	200
Max PCB thickness (mm)	=	3.20	3.20	2.40	2.00	1.60



or 8-7 and 7-6, but not both. This lets our customers design with those fine-pitch BGAs, where cost is manageable since the HDI is limited to only a small area and to two microvia 'runs'.

In Practice

What does this mean in practice? Let's look at Pattern Class 7 with Drill Class E from **Figure 2**, where the smallest pad diameter possible is 0.45 mm (0.1 + 0.35 mm); that won't fit inside most fine pitch BGA pad diameters. However, when we use the same classification together with the HDI pool, the smallest diameter becomes 0.28 mm, which will fit! This allows designers to place vias in the centre of BGA pads without needing to enlarge the pads beyond the manufacturer's recommendations. The smaller microvia pads also mean that using dogbone patterns becomes a possibility.

Obviously, it's impossible to cover all BGA pin arrays and their pin configurations in order to determine which part will be routable and which won't. However, we have configured our pool parameters such that full 8x8 arrays should be fully routable for BGAs down to 0.4 mm pitch. (**Figure 3** shows an example of a fully fanned-out 8x8 0.4 mm pitch part.) But of course, larger arrays are possible too, and it all depends on the array size, pin configuration, and how those pins

are used. In many packages, there are No Connect pins, and in most designs not all pins of a microcontroller or processor are used, which may ease routing-out large BGA arrays with only two microvia 'runs'.

What now? We invite you to upload your designs to our Visualizer [1] and check them for manufacturability. As always, we welcome your feedback on how this service may solve your manufacturing issues. [▶](#)

240593-01

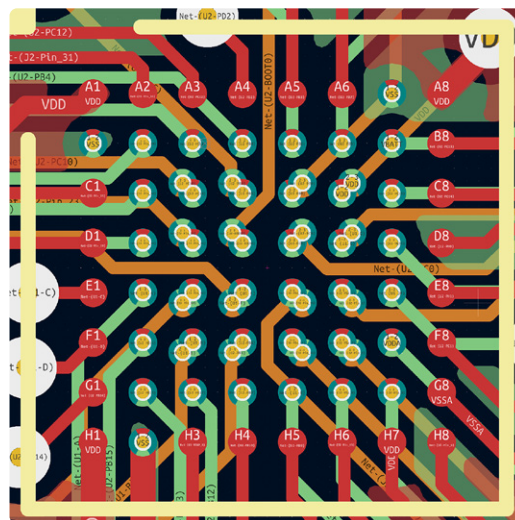

Figure 2: The parameters of our Pattern classes for which HDI pool is available (note that Pattern Class 9 isn't poolable.)

Figure 3: An example fan-out of an STM32F412 in a WLCSP64 0.4 mm pitch package. The first BGA 'ring' is routed on the top layer (red), the second ring on the second layer (green) using L1-L2 microvias in the centre of pads, and the third and fourth rings are routed on the third layer (orange) using L1-L2 and L2-L3 staggered vias.

WEB LINK

[1] <http://be.eurocircuits.com/shop/orders/configurator.aspx?loadfrom=web&service=hdipool&lang=en>

The Ultimate Tool for Every Electronics Enthusiast

Unlock Endless Possibilities with Red Pitaya and 1,000+ Click Boards™

Contributed by Red Pitaya

If you're an electronics enthusiast looking to elevate your projects, a Red Pitaya board is the tool you need. This revolutionary, open-source platform combines multiple instruments into one compact device, making it a must-have for engineers, hobbyists, and researchers. Often called the Swiss Army knife of electronics, a Red Pitaya board replaces bulky lab equipment such as oscilloscopes, signal generators, and spectrum analyzers — delivering powerful functionality in a compact, credit-card-sized, and affordable package. With its open-source design, it also fosters innovation by allowing users to develop and share custom applications, making it the ultimate all-in-one solution for your electronics projects.

Why Choose Red Pitaya?

› **Versatility at its best:** A Red Pitaya board can adapt to a wide range of applications, from signal processing and telecommunications to robotics and IoT projects. Its modular design means you can always tailor it to your specific needs.

- › **Cost-effective innovation:** Say goodbye to expensive, specialized equipment. A Red Pitaya board offers high-end functionality without breaking the bank, making advanced electronics accessible to everyone.
- › **Portability and convenience:** The compact, credit card size of a Red Pitaya board means you can take your lab anywhere. Whether you're in the field or at your desk, Red Pitaya is your constant companion.
- › **Open-source community:** Join a global network of enthusiasts and professionals who share applications, tutorials, and ideas. With extensive documentation and support, you'll never feel lost.

Introducing the Red Pitaya Click Shield: Unleash Infinite Possibilities

As if Red Pitaya weren't versatile enough, the new **Red Pitaya Click Shield** takes it to an entirely new level. This innovative expansion board allows you to connect over **1,000 different Click boards™** from MikroElektronika, opening a world of possibilities. These plug-and-play modules include everything from sensors and communication interfaces to motor controllers and displays. With the Red Pitaya Click Shield, integrating new functionalities into your projects has never been easier.

What Is the Red Pitaya Click Shield?

The Red Pitaya Click Shield acts as a bridge between Red Pitaya and the extensive range of Click boards™. It enables integration without the need for complex wiring or advanced technical expertise. Simply attach

the Red Pitaya Click Shield to your Red Pitaya, plug in your chosen Click boards™, and you're ready to innovate.

How Can It Help Your Projects?

- › **Endless customization:** Imagine adding any functionality you need with minimal effort. Need to monitor environmental conditions, control motors, or implement wireless communication? There's a Click board™ for that!
- › **Ease of use:** Designed for seamless integration, the Red Pitaya Click Shield eliminates complicated setups. No soldering or intricate wiring — just plug your Click board™ in and start working.
- › **Cost-effective expansion:** Enhance your Red Pitaya's capabilities without investing in multiple specialized devices. The Red Pitaya Click Shield offers a budget-friendly way to expand the scope of your project.
- › **Community support:** With a vast user community and extensive documentation, you'll have all the resources you need to succeed. Share ideas, find inspiration, and get help when you need it. ◀

240590-01

Visit us at the electronica 2024 fair, booth A3/572!

We're thrilled to showcase our Red Pitaya boards and the new Click Shield at the upcoming **electronica, from 12 to 15 November in Munich**. Whether you're a seasoned engineer or new to electronics, this is your chance to see firsthand how this versatile platform can revolutionize your projects.

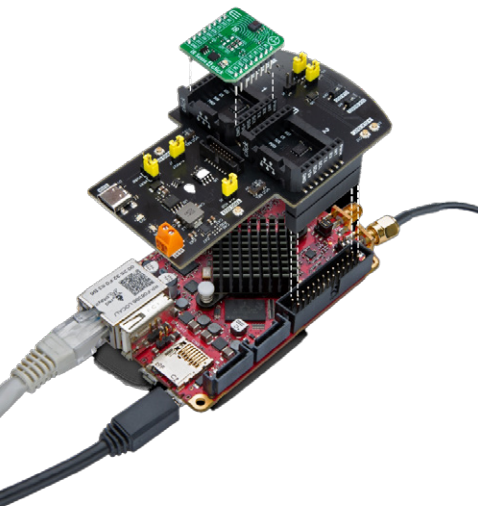

ASUS IoT Amston Lake SBC

With **Intel® Deep Learning Boost**, the SBC enables up to **6x faster AI processing**, ideal for complex tasks such as advanced machine learning and image processing.

The Asus IoT Amston Lake SBC is based on the **Intel® Atom™ x7000RE series** and doubles the number of cores without increasing power requirements.

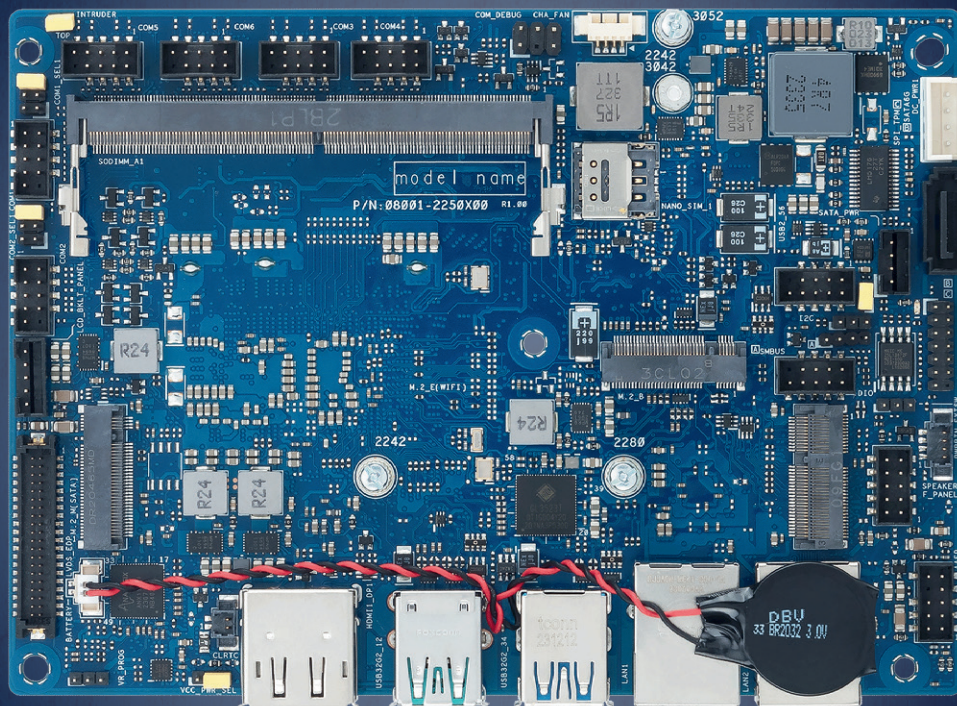

The SBC offers up to **16 GB DDR5 RAM** with **in-band ECC**, which thus ensures maximum performance and also **minimum susceptibility to errors** in edge computing applications.

Designed for temperatures from **-20°C to +70°C** and with a very wide input voltage range of **9-36V**, the board is ideal for harsh industrial conditions.

FORTEC
INTEGRATED

Interested in our products?



PECULIAR

PARTS

Unusual ICs

By David Ashton (Australia)

Let's take a look at the fascinating evolution of integrated circuits (ICs) through the decades, from unique and peculiar early designs to today's compact, standardized packages.

These days, integrated circuits (ICs) come in ever smaller packages, but in only a few standard types — surface mount device (SMD) types with ever finer lead pitches, and Ball Grid Arrays (BGA) where the connections are all underneath the IC. The older through-hole types — beloved by hobbyists without specialist equipment — are still around, but becoming rarer as time goes on.

In the old days (I'm showing my age here) we had a multiplicity of IC packages, some beautiful, some ugly, but all peculiar compared to today's ICs.

Through-Hole ICs and Larger Packages

These days, you are not very likely to see through hole ICs in anything larger than a 40-pin, 0.6-inch wide package. Anything bigger will be SMD. But in days of yore, up to 64-pin packages were not too uncommon. Here's one — a 64-pin HD68450 DMA IC for Motorola's 68000 series microprocessors (**Figure 1**). It's also in a ceramic package; I think ceramic substrates had better thermal stability than plastic, but were usually more expensive.

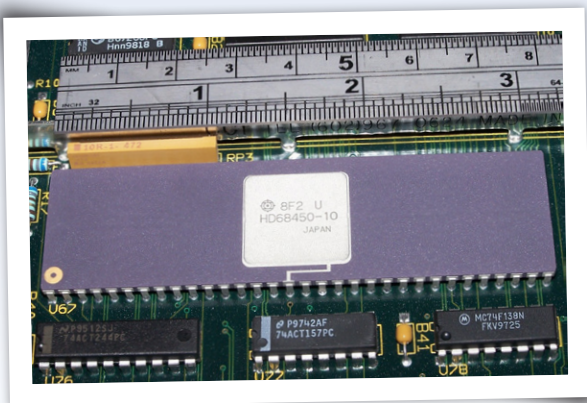

Figure 1: HD68450 DMA IC for Motorola's 68000 series microcomputers, in a ceramic package.

From the same era were EPROMs — Erasable, Programmable Read-Only Memory (**Figure 2**). They came in fairly standard 24- to 40-pin packages, but had a quartz window on the top of the package. You programmed them electrically, but to erase and re-use them, you exposed them to UV light through their little window. The chip dies themselves diffracted light at the right angle and showed beautiful colors.



Figure 2: A selection of EPROMs.

One trick that manufacturers made use of to get more pins in a smaller area was to use quad-in-line packages, with pins taking two lines of holes on each side of the chip. This let manufacturers put the leads closer together without needing smaller pads on the PCB. You can see a large-sized one in **Figure 3**.

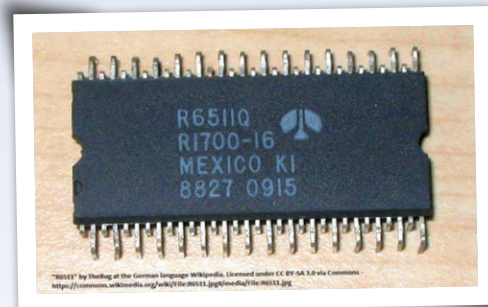

Figure 3: Quad-in-line RS6511 IC. Source: Guido Körber / Wikimedia Commons, CC BY-SA 3.0.

Strangely enough, the same technique was used for much smaller ICs — Motorola made an electronic attenuator called the MFC6040 with 6 pins (**Figure 4**). Why they didn't just produce these in a standard 8-DIL package, I don't know...

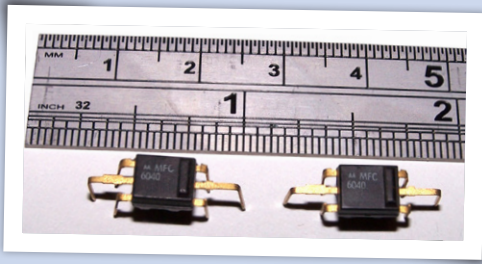

Figure 4: Six-lead quad-in-line MFC6040 attenuator.

Of course, before we had DIL ICs, we had the round TO-99 packages for op-amps and even some old digital ICs. The early 709 and 741 opamps were very common in this package. They were called TO-99 when they had 8 or 10 pins (I have seen TO-74 used for 10-pin types) and TO-5 or TO-39 when they were just 3-lead transistors. It's surprising what you can find in these old round packages — I even have some 555 timers in them. An assortment of these ICs is seen in **Figure 5**. This was the common package for early ICs of all types.



Figure 5: TO-99 8- and 10-pin ICs.

Heatsinking small audio amplifiers is always a problem. Higher power amps can be put in one of the tabbed packages like voltage regulators and power transistors, but some attempts were made to do it with smaller (around 5 W) amplifiers. The results are pretty ugly (**Figure 6**). The TAA621 had a quad-in-line pinout, with the heatsink glued to a plastic IC, and the Plessey SL403D was a 10-pin DIL IC with the chip actually mounted on the heatsink. But both these amps were notoriously unreliable....

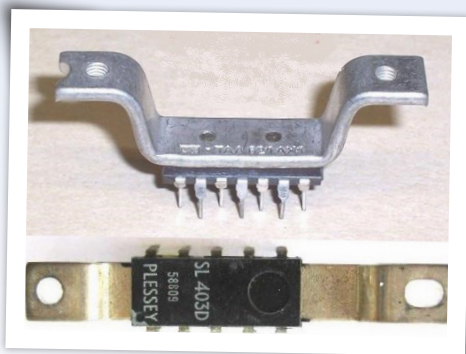

Figure 6: Audio amplifiers with heatsink. A quad-in-line TAA621 (top), and a Plessey SL403D (bottom).

Making It Big

I've saved the best 'til last! This monster (**Figure 7**) consists of a square ceramic base nearly 3 inches on a side, with three separate big SMD ICs mounted on it, along with a few SMD capacitors and one resistor. So, I guess technically it's a hybrid circuit, not an IC per se, but it is pretty. One of the ICs has a round heatsink mounted on it like a helipad. It is a CYM7232S40HGC 32-bit DRAM Accelerator from an early 1990s server. 371 pins (my count) and a huge socket came with it.

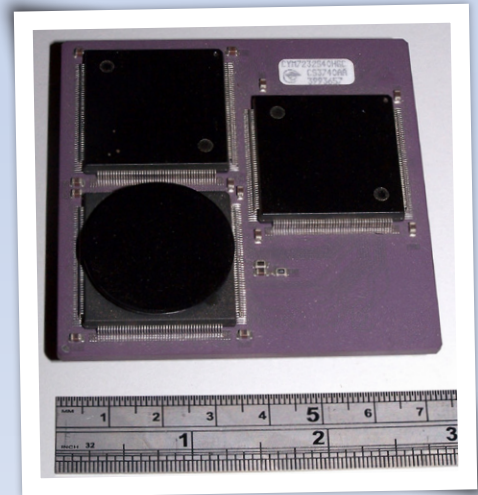

Figure 7: Early 1990s DRAM accelerator IC.

This is a by no means exhaustive look at some of the more peculiar IC packages that have been around in the past. Looking at today's QFP, QFN and BGA packages, I'm not sure if things are any easier, especially for us hobbyists! ◀

240417-01



About the Author

David Ashton was born in London, grew up in Rhodesia (now Zimbabwe), lived and worked in Zimbabwe, and now lives in Australia. He has been interested in electronics since he was "knee-high to a grasshopper." Rhodesia was not the center of the electronics universe, so adapting, substituting, and scrounging components were skills he acquired early (and still prides himself on). He has run an electronics lab, but has worked mainly in telecommunications.

Questions or Comments?

If you have technical questions or comments about this article, feel free to contact the Elektor editorial team by email at editor@elektor.com.

Rising to the Top: Industrial 3D Printers

In 2023, industrial 3D printers dominated the global market, accounting for approximately 76% of the total revenue due to their extensive use in producing intricate and accurate components across various heavy industries. Meanwhile, desktop 3D printers, initially popular

among hobbyists, are gaining significant traction. The "entry-level" segment, comprising printers priced at \$2,500 and below, saw a 9% year-over-year growth in Q3 2023 [6]. Companies like Creality, Anycubic, and Bambu Lab are key players in this segment. The rise of "fabshops" in

the U.S., offering on-demand 3D printing services, further highlights the increasing demand for desktop printers alongside the continued dominance of industrial printers.

Key 3D Printing Methods

Emerging 3D printing technologies such as stereolithography (SLA), selective laser sintering (SLS), and fused deposition modeling (FDM) are gaining momentum, offering specialized solutions. SLA is renowned for its precision in creating intricate details, SLS is favored for its ability to produce durable, functional parts without the need for support structures, and FDM is widely used for its versatility and cost-effectiveness in prototyping and low-volume production.

Stereolithography led the market in 2023, with 10% of global revenue [3], due to its reliability and ease of use. FDM represented a significant portion of revenue in 2023 due to widespread adoption in various 3DP processes.

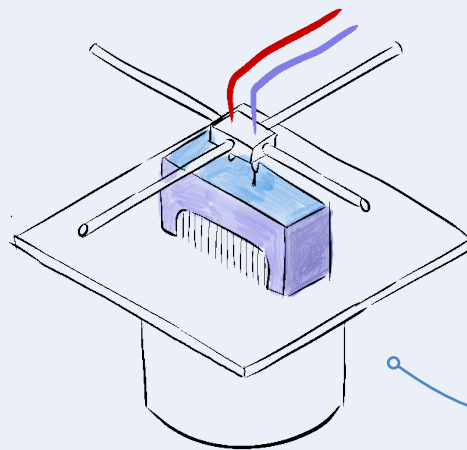

FDM

Fused Deposition Modeling

- > Melts and extrudes thermoplastic filament
- > Lowest price of entry and materials
- > Lowest resolution and accuracy

BEST FOR:

Basic proof-of-concept models and simple prototyping

SLA Stereolithography

- > Laser cures photopolymer resin
- > Highly versatile material selection
- > Highest resolution and accuracy, fine details

BEST FOR:

Functional prototyping, patterns, molds and tooling

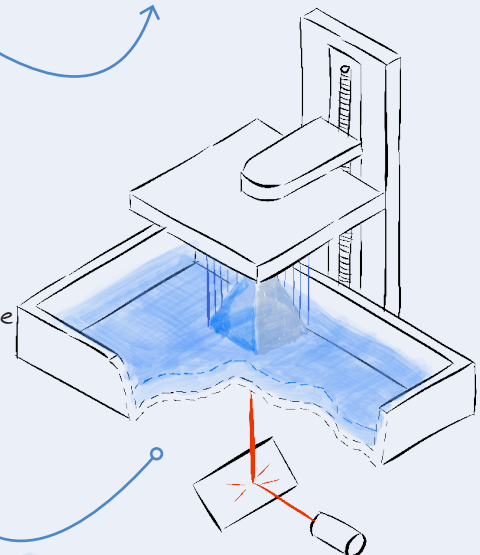

SLS Selective Laser Sintering

- > Laser fuses polymer powder
- > Low cost per part, high productivity, and no support structures
- > Excellent mechanical properties resembling injection-molded parts

BEST FOR:

Functional prototyping and end-use production

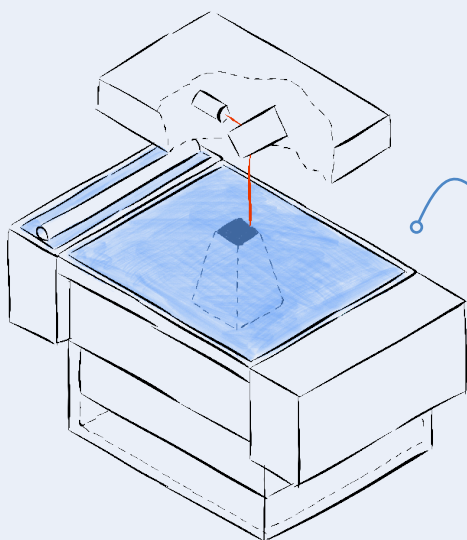

Source: 3D Printers Perth

3D Printing: A Closer Look at the Latest Stats

The 3D printing industry is becoming more accessible to a wider audience [1], as the distinction between consumer and professional-grade machines diminishes. Affordable, high-quality 3D printers are allowing more businesses to incorporate this technology into their daily operations. This is accelerating market growth [2] and promoting innovation among established companies. The trend indicates that 3D printing will soon be as common and attainable in workplaces as traditional office printers, transforming how businesses approach manufacturing and design.

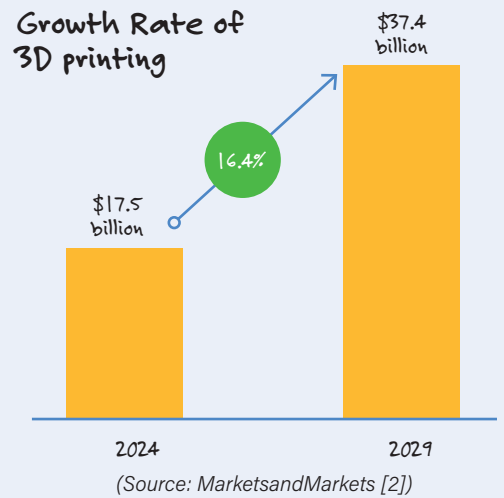

54%

of global revenue in 2023 for the prototyping segment in the 3D printing market [3].

23%

of global revenue in 2023 for the automotive sector in the 3D printing market [3].

CNC Machining: Comparing Milling and Turning

The traditional manufacturing methods such as injection molding and CNC machining still play a significant role as alternatives to 3D printing, especially for mass production and high-precision requirements.

Turning Vs Milling Overview

Turning	Milling
Roundbar	Square/Rectangular Block
Cylindrical or conical	Rectangular/Square
Lathe	Milling machine
Turning Workpiece: Rotates Cutting Tools: Stationery	Workpiece: Stationery Cutting Tools: Rotates

Source: Pioneer Service Inc.

Applications

CNC Milling

Used for complex shapes: gears, molds, intricate parts

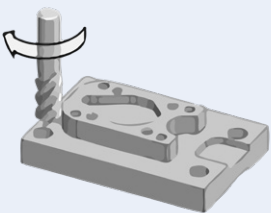

CNC Turning

Ideal for cylindrical parts: shafts, bolts, symmetrical components

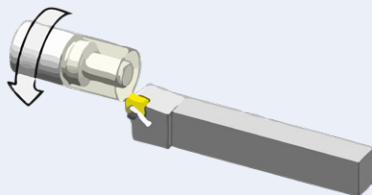

240427-01

WEB LINKS

- [1] C. Schwaar, "A 3D Printer On Every Desk? Why Companies Are Buying More 3D Printers," Forbes, May 2024: <https://tinyurl.com/desktop-3d-printers>
- [2] MarketsandMarkets, "3D Printing Market," 2023: <https://tinyurl.com/mam-3d-printing>
- [3] GVR, "3D Printing Market Size & Trends," 2023: <https://tinyurl.com/gvr-3d-printing>
- [4] 3D Printers Perth, "FDM vs SLA vs SLS 3D Printers": <https://tinyurl.com/fdm-vs-sla-vs-sls>
- [5] Pioneer Service Inc., "Turning Vs. Milling: What's the Difference for Machining?," 2020: <https://tinyurl.com/turning-vs-milling>
- [6] Kety S., "The 'fall and rise' of desktop 3D printing," 3D ADEPT Media, July 2024: <https://3dadept.com/business-the-fall-and-rise-of-desktop-3d-printing/>



Andonstar AD409 Pro-ES HDMI Digital Microscope

It's Tall and Has an Endoscope

By Clemens Valens (Elektor)

The Andonstar AD409 Pro-ES is what they call an HDMI digital microscope. It features a 10" HDMI display and a camera with a long magnifying lens attached to it. This assembly is mounted on an adjustable stand, allowing precise positioning. With the microscope, you can inspect, for instance, electronic circuit boards and other smallish objects.

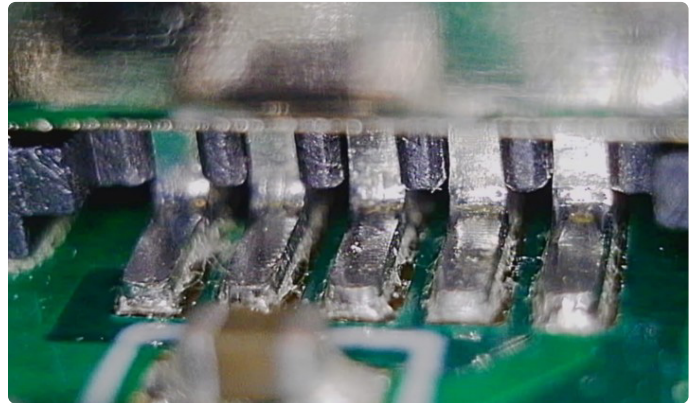

Figure 1: A resolution of 5,600×4,200 pixels allows for plenty of detail.

The microscope is not well suited for medical or biological applications, as the maximum magnification ratio is 300 times. This is not enough for observing cells and similar things. The magnification ratio is, however, more than sufficient for viewing electronic assemblies.

HDMI does not only refer to the microscope's display. It also means that the device has an HDMI output that can connect to another (larger) display. Only one display can be active at any time, so you must choose between the AD409's display and the external display.

Use the Andonstar AD409 to Capture and Export Videos and Photos

Besides simply viewing, the microscope can also record videos (MP4, four resolutions from UHD 2,880×2,160 @ 24 fps to HD 1,280×720 @ 120 fps) and take photographs (with a resolution of up to 5,600×4,200 pixels), as shown in **Figure 1**. The microscope stores these on a microSD card (up to 64 GB) but the files are also accessible over USB. Therefore, they are easy to export to the accompanying PC application that is available for further image analysis.

The PC tool (Microsoft Windows only) lets you annotate an image and take all sorts of precision measurements of details in the image. It also has a few basic image enhancement functions, and it can control some functions of the microscope remotely.

Four AD409 Versions

The AD409 comes in four versions: AD409, AD409 Pro, AD409 Max Pro and AD409 Pro-ES. The optical/camera/display system is identical for all four of them — the differences are in the options included in the box. I already had a close look at the AD409 in another article [1]; therefore I will not go into these details again.

Taller Stand With More Features

Compared to the AD409, the AD409 (Max) Pro and AD409 Pro-ES have a different, higher, and more elaborate stand (**Figures 2 and 3**). On the AD409 this is just a short column, whereas the (Max) Pro and Pro-ES add a bracket to it. This allows moving the microscope vertically up and down, and horizontally toward and away from the user. It can also rotate 360° around the center column. The column itself can tilt backwards and forward, meaning that it offers plenty of freedom of movement for the camera. An adjustable ring sliding up and down the columns can serve as either a height preset or as a protection against lowering the microscope too much.

Plenty of Clearance

I measured a maximum of 25.3 cm of clearance between the lens and the baseplate (7.7 cm for the AD409). Rotating the camera 90° to the left or right adds another 12 mm (but be careful that

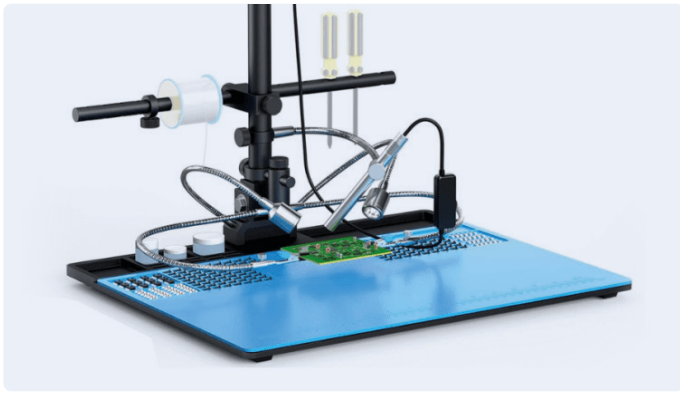

Figure 2: The AD409 Max Pro has a large, silicon-clad baseplate, a toolholder bar and flexible arms for holding a PCB or other object.

the instrument doesn't tip over). This is plenty of space not only for large objects, but also for your hands with tools in them. It also means that the microscope is over 50 cm tall and may wiggle a bit if you bump into the bench.

The AD409 Pro-ES Adds an Endoscope

The AD409 Pro-ES is the top model of the HDMI digital microscope range and includes, besides the Pro stand, an endoscope. The endoscope is a pen-shaped camera with a diameter of almost 13 mm. It comes with a flexible arm that attaches to the column (adjustable height). It doesn't magnify, but it has a dimmable white LED ring built in to light the subject of interest or to see inside it (Figure 4).

The HDMI display can switch between the microscope camera and the endoscope. There is also a mode where the endoscope image is overlaid on a quarter of the camera image, giving you two different views of the subject at the same time.

A Real Close Look

The fact that the endoscope doesn't magnify isn't a problem, as you can position it really close to the subject of interest. This way, even tiny details become large and visible, as shown in the image capture from Figure 5. The endoscope is excellent for looking at, for instance, solder joints under USB connectors. The focus is adjustable with a ring at the rear end of the device. Make sure to tighten the endoscope's flexible arm grip very well; otherwise the camera may rotate while you try to adjust its focus.

Even though the flexible arm is practical, it lacks some stability while adjusting the focus, making the image move. Note that adjust-

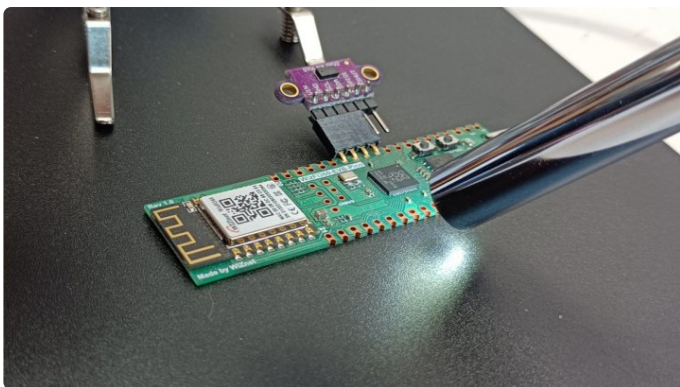

Figure 4: The endoscope with built-in LED ring lets you look at details from a different angle. It can also look inside objects.



Figure 3: The Andonstar AD409-Pro (ES) is a full head taller than the AD409.

ing the focus of the microscope camera has a similar effect, but it is less of a problem.

Looking Around the Corner

The typical use of an endoscope is to look inside subjects and pipes, and for this, it comes with a few practical accessories that slide over the camera tip. As an example, a side-view mirror provides a periscopic view, allowing you to look around the corner, behind an object. Two other specula let you inspect holes with diameters smaller than the endoscope. Finally, the LED ring of the endoscope is useful as a third light source for the microscope's camera.

I did not find technical specifications for the endoscope, so I know neither its resolution nor if it provides the same video recording quality as the microscope camera. To find out, I tried taking pictures and videos. This brought up some issues.

The AD409 Pro-ES and SD Card Issues

According to the manual, the AD409 accepts 64 GB Class 10 microSD cards. I happened to have one that I had formatted on my PC. Taking photographs worked, but trying to record a video produced an error. Therefore, I used the microscope to reformat the SD card, but that didn't help. Replacing the SD card with an 8 GB type solved the problem. Now I could record video and photographs. However, after setting the video resolution to UHD P24 (the highest), things stopped working. It became impossible to record videos or take photographs, and the menu button on the remote control had stopped working too. All other functions worked normally, though. Rebooting the microscope solved the problem, as the microscope doesn't (seem to) keep (all of) its settings between power cycles.

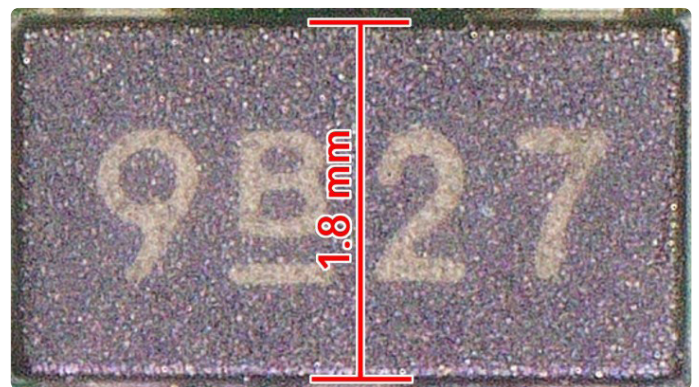

Figure 5: High-quality image capture allows for precise measurements.

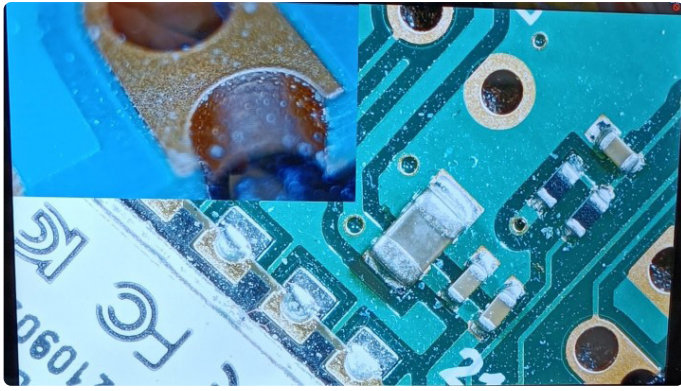

Figure 6: Picture-in-picture display showing endoscope and microscope images simultaneously.



Figure 7: The Andonstar AD409 Pro-ES also has a remote control.

Record Video From Two Cameras at Once

It took me a while to figure out how to select the camera that is used for recording a video. As it turns out, this is done when you set the video resolution. Opening the video resolution menu shows a list of possibilities. There are two entries that look a bit strange: *HD P30+HD P30* and *FHD P30+FHD P30*. If you choose one of these, the microscope will record from both cameras at the same time (**Figure 6**) (which is pretty cool, I think). On the SD card you will find two files, one with a name ending in “A” (microscope) and the other in “B” (endoscope). All other video resolutions only apply to the microscope camera.

Also Works for Taking Pictures

Photographs are always taken from both cameras at the same time, irrespective of the resolution. Taking photographs at the highest resolution (5,600×4,200) is thus possible with both cameras (even though I am not convinced that the endoscope really has that many pixels). As with video files, photographs with filenames ending in “A” correspond to the microscope, while filenames ending in “B” were captured by the endoscope.

Capable Instrument

The Andonstar AD409 Pro-ES HDMI digital microscope is a very capable instrument for visual inspection of small objects and details (**Figure 7**). With its magnification ratio of 300×, it may not be suitable for medical usage, but it is perfect for looking closely at solder joints and super tiny SMT components, for example.

The endoscope of the “ES” version is great for looking at the subject of interest at another angle than from above, from very nearby, or even from the inside. When you don’t need it as a camera, it is still useful as a third adjustable spotlight.

High-Quality Image Capturing with the AD409 Pro-ES

Both the microscope and endoscope can be used for recording high-quality videos or taking photographs at the same time. However, only the microscope can record UHD P24-resolution videos.

The extra-tall column provides plenty of space for moving the subject and/or your hands around without the risk of bumping into the camera. The independent horizontal and vertical position controls let you aim the microscope at almost any point on the subject without moving the latter.

The Andonstar AD409 Pro-ES HDMI digital microscope makes for an excellent addition to any electronics workspace and lab, but also for other applications that require close inspection of tiny details. ◀

240453-01

Questions or Comments?

Do you have any questions or comments related to this article? Email Elektor at editor@elektor.com.



FEATURED TOPIC



Visit our **Prototyping & Production page** for articles, projects, news, and videos.

www.elektormagazine.com/prototyping-production



Related Products

- > **Andonstar AD409 10.1" HDMI Digital Microscope**
www.elektor.com/19681
- > **Andonstar AD409 Pro-ES 10.1" HDMI Digital Microscope (incl. Endoscope)**
www.elektor.com/20427
- > **Andonstar AD409 Max-ES 10.1" HDMI Digital Microscope (incl. Endoscope)**
www.elektor.com/20852
- > **Andonstar AD210 10.1" Digital Microscope**
www.elektor.com/20802

WEB LINK

[1] C. Valens, “Get Precise with the Andonstar AD409 Digital Microscope,” elektormagazine.com, May 2021: <https://elektormagazine.com/news/get-precise-with-the-andonstar-ad409-digital-microscope>



From design To Product

PCB/PCBA Design

PCB/PCBA Production

**Best
Price**

Centralized
production to
reduce costs

**Top
Quality**

Reliable quality
from established
factory

**Real
Service**

Professional
customer service
available online

**Rapid
Speed**

Product
delivery in as
fast as 3 days

5.4M +

Customers

6000 +

Employees

14.5M +

Orders/year

9M +

PCBs
Produced /year

Register to receive

\$60 new user coupon

\$24 SMT service coupon every month

jlcpcb.com

**scan to
get 10\$
exclusive
coupon**

